

**ELECTORAL COMPETITION, POLITICAL
UNCERTAINTY AND POLICY INSULATION**

Rui J. P. de Figueiredo, Jr.

Assistant Professor

Haas School of Business and Department of Political Science

University of California at Berkeley

545 Student Services Building #1900

Berkeley, CA 94720-1900

phone: 510 642 6452 fax: 510 643 1412

email: rui@haas.berkeley.edu

Working Paper 2001-7

***Working Papers* published by the Institute of Governmental Studies provide quick dissemination of draft reports and papers, preliminary analysis, and papers with a limited audience. The objective is to assist authors in refining their ideas by circulating results and to stimulate discussion about public policy. *Working Papers* are reproduced unedited directly from the author's page.**

Electoral Competition, Political Uncertainty and Policy Insulation

Rui J. P. de Figueiredo, Jr. **

Assistant Professor

Haas School of Business and Department of Political Science

University of California at Berkeley

545 Student Services Building #1900

Berkeley, CA 94720-1900

phone: 510 642 6452 fax: 510 643 1412

email: rui@haas.berkeley.edu

First Version: October 1997

This Version: August 2000

ABSTRACT

Scholars argue that electoral uncertainty is a crucial factor that influences policy implementation: current holders of public authority, nervous that they might lose their position, seek to insulate the agencies they create so that policies will survive their creators. These theories, however, ignore crucial variation in the electoral prospects of groups competing for public authority. In this paper, I examine the effect of electoral volatility on the degree to which groups in power will dismantle their opponent's agencies and programs and insulate their own policies from such destructive behavior. Through the analysis of two repeated games, I derive four propositions which fully characterize the conditions under which cooperative behavior can provide stability in the face of electoral uncertainty and instability. First, I show that if gains from cooperation are sufficiently large, compromise and cooperation can occur in the face of uncertainty. Second, I show that electoral uncertainty *increases* the possibility of cooperation, a result counter to the informal literature. Third, when electoral uncertainty is low, only one group—that with a low probability of electoral success—will insulate their programs. Finally, as electoral uncertainty *increases*, a wider set of the parameter values support the extreme cases of either both insulating or not insulating. I conclude by discussing some implications, examples and potential further extensions of the models.

** Haas School of Business and Department of Political Science, University of California at Berkeley. The author gratefully acknowledges Michael Bailey, Jonathon Bendor, Kelly Chang, John Ferejohn, Brian Gaines, Douglas Grob, Terry Moe, Douglas Rivers, Kenny Schultz, Pablo Spiller, David Sturtz, Andy Tsay, and Barry Weingast, and three anonymous reviewers, for helpful comments and conversations. I am also grateful for the helpful comments from panel participants and discussants at the 1996 Annual Meeting of the American Political Science Association, September 1, 1996, San Francisco, CA, the 1996 Western Economic Association Annual Meetings, June 30, 1996, San Francisco, CA, and seminar participants at Johns Hopkins University, Massachusetts Institute of Technology, Northwestern University, Ohio State University, Princeton University, Stanford University, University of California-Berkeley, University of California-Davis, University of California-Los Angeles, University of Chicago, and University of Rochester. All faults remaining are solely due to the author.

Free elections are central to the institutional structure of democratic governments. As Hamilton noted in the *Federalist Papers*, elections create "an immediate dependence on, an intimate sympathy with, the people" (Hamilton, Jay and Madison 1966: 165). But although elections establish an ongoing connection between representatives and citizens, their impact on policy implementation is less clear. "[We must recognize] the intimate connection between the duration of the executive magistrate in office and the stability of the system of administration," Hamilton continued. "To reverse and undo what has been done by a predecessor is very often considered by a successor as the best proof he can give of his capacity and desert...the less [the successor] resembles [the predecessor], the more he will recommend himself to the favor of his constituents" (Hamilton, Jay and Madison 1961: 436-439). Despite this early warning, existing scholarship on the determinants of the structure and performance of the bureaucracy has largely ignored the effects that electoral volatility has upon policy implementation.

There are two literatures that address the issue of why public organizations are structured in particular ways. The first addresses the problem of how elected officials can use structure to control agencies. A number of scholars have shown that organizational design, administrative procedures, and other aspects of organization structure, can provide elected officials with a means of overcoming agency problems. According to this scholarship, structural choices are the product of a struggle between independent-minded bureaucrats and their political fathers (Weingast and Moran 1983; McCubbins, Noll and Weingast 1987; Fiorina 1983; Ferejohn and Shipan 1983; Bawn 1995; Epstein and O'Halloran 1994; Lupia and McCubbins 1994; Epstein and O'Halloran 1999; de Figueiredo, Spiller and Urbiztondo 1999). A second literature adds a dynamic perspective. This literature, exemplified by Moe, argues that elected officials are keenly aware of the likelihood of their own demise. Therefore, they provide structural insulation mechanisms which allow their policies to survive a loss of public authority. In this context, organizational design can be seen as a product of the political uncertainty with which political actors live (Horn 1995; Moe 1989, 1991).

While both of these literatures provide us with a better understanding of why public policies and agencies look the way that they do, they both ignore crucial aspects of variation in the strategic calculus of a policy's creators. Although the former takes account of a crucial

intra-temporal dynamic—the agency relationship between elected officials and bureaucrats—it ignores the *inter-temporal* highlighted by Moe. The latter addresses this question specifically—noting that political uncertainty is the crucial aspect of inter-temporal variation—but it ignores the fact that political uncertainty is a *variable*.

This paper elucidates the contingent effects of the *degree* of electoral uncertainty through the analysis of an infinitely repeated, non-cooperative game. I derive the conditions under which reciprocity and cooperation can provide stability in the face of electoral uncertainty and instability. I then use this framework to examine the effects that electoral uncertainty has on the nature of agency structure and policy implementation. The paper proceeds as follows. In section 1, I review the major bodies of literature on agency accountability, structure and performance, highlighting the inadequate treatment of electoral institutions. In section 2, I present a simple reciprocity game to analyze the effects of random recognition on the possibility of cooperation. In this model, insulation is not available. I find that, in this setting, as electoral uncertainty *increases*, the set of parameters over which cooperative outcomes are possible becomes larger. Further, I demonstrate that this is an extremely general result, holding in cases where conflict over occurs on a single dimension and when control over public authority is separated, raising the possibility of divided government. In section 3, I consider a richer application of the reciprocity game to consider what effect if any, such repeated play has on the decision to erect protective structures around an agency, to hinder interference. This model provides theoretical evidence for a richer picture of intertemporal agency structuring decisions.¹ In Section 4, I provide two examples that illustrate the mechanisms highlighted by the models. First, I analyze the development of radio regulation and the inception of the Federal Communications Commission (FCC). Second, I reinterpret recent scholarship concerning tariff policy during the late nineteenth and early twentieth centuries. Both of these cases serve to illustrate the mechanisms at play in the theoretical model. Finally, in Section 5, I offer a concluding discussion.

¹ In this sense, the paper is in the spirit of a number of recent models from economics which consider the dynamic effects of politics on macroeconomic policy (see, e.g. Alesina and Drazen 1991, Besley and Coate 1998, and Coate and Morris 1999).

1. Current Views on Agency Structure

A large body of literature has attempted to explore the nature of bureaucratic discretion. An early view held that bureaus were able to exercise discretion because of agency problems—since elected officials were viewed as distant from policy implementation, bureaucrats are able to turn their private knowledge about both issue areas and their own actions to the bureau's advantage, shirking their responsibilities and implementing policies of their own design. In *Bureaucracy and Representative Government*, William Niskanen produced one of the first formal treatments of this argument. Employing an economic supply and demand model, he argues that these advantages mean that budget-maximizing agencies can garner appropriations far in excess of the legislature's ideal (Niskanen 1971; Bendor 1989). Wilson reiterates this point about the unique nature of government agencies—multiple principles, vague or conflicting goals, and the inability to impose monetary performance rewards, mean that there is a vast potential for "bureaucrats with policy preferences" to impose their own will on the implementation of government policy (Wilson 1989). The Niskanen view had apparent validation in the fact that the exercise of control is only rarely observed—Congress infrequently holds hearings, agencies are only occasionally restructured, and budgets are ever increasing as the bureaucracy grows, uncontrollably in the view of some. Dodd and Schott, for example, comment that "although we find the amount of oversight activity has increased, its effectiveness is open to serious question..." (Dodd and Schott 1979, 270).

Following the development of the view that bureaus are autonomous actors, a number of scholars attempted a revision, ascribing a greater degree of control to both Congress and the President. These scholars point out that just because control *activity* is minimal, this is not evidence for a *lack* of control. A series of studies has demonstrated that officials can use a variety of mechanisms to effectively control government agencies, many which can operate without visible punishments and rewards (Weingast and Moran 1983; McCubbins, Noll and Weingast 1987, 1989; Fiorina 1983; Ferejohn and Shipan 1983; Bawn 1995; Epstein and O'Halloran 1994; Lupia and McCubbins 1994; Epstein and O'Halloran 1999; de Figueiredo, Spiller and Urbiztondo 1999). McCubbins and Schwartz, for example, argue that control does not have to be active. In fact, in many cases, it is optimal to install effective compliance

monitoring mechanisms and then manage by exception (McCubbins and Schwartz 1984). Similarly, a number of scholars, including Kiewiet and McCubbins, McNollgast, Horn, and Calvert, McCubbins and Weingast, find that delegation decisions are strictly political (Kiewiet and McCubbins 1991; McCubbins, Noll and Weingast 1987, 1989; Horn 1995; Calvert, McCubbins and Weingast 1989; Epstein and O'Halloran 1999). If elected officials, or interest groups, want to have direct control, they will. When agencies act independently, it is for one of two reasons. On the one hand, officials might not want control. As Arnold explains, often times, legislators do not want to be held accountable for policy decisions, and delegating authority to autonomous bureaus allows congressmen to avoid blame for policy intransigence by fingering the independent bureaucracy (Arnold 1990). On the other hand, as Calvert, McCubbins and Weingast, argue, legislators can use *ex ante* structural choices to ensure that an agency will conform to officials' wishes. This means they can then delegate to the agency without fear of malfeasance. As they explain of their findings, "...[T]he executive or legislature can take, prior to agency choice, [actions] that influence the later goals of the agent or the set of feasible choices available to the agency. Such actions include the structuring of the agency itself, the denomination of its powers and jurisdiction, the specification of administrative procedures to be followed, and the type of personnel with which the agency is to be staffed" (Calvert, McCubbins and Weingast 1989: 604).

This vein of the scholarship on delegation suffers from a significant shortcoming. While all of this literature demonstrates the way in which a legislature or president can overcome basic moral hazard problems—either a lack of effort or implementation of a new policy position—the actors in these models are static. In democracies, however, elected officials and the interests they represent will change. This means that agencies are not the only actors who threaten the future implementation of the officials' or group's target policy. In addition, *current* officials must be concerned that *future* holders of public authority will undo what has been accomplished in the present period. Unfortunately, since the actors never change in most of the control and delegation models, these studies leave this fundamental design problem largely unexplored.

One scholar who takes account of these intertemporal effects is Moe, later followed by others such as Rothenberg and Horn. Moe recognizes that the bureaucratic structures winning

groups erect are subject to possible sabotage by future winners (Moe 1991).² According to Moe, the potential for such destructive behavior means that today's winners must install protective mechanisms against the future actions of one's opponents (Moe 1989). In the context of American bureaucracy, this means that prevailing groups will legislate a number of "insulation mechanisms" to ensure that their creation is not undermined. Among these tools, Moe cites writing detailed legislation which "imposes rigid constraints on the agency's mandate and decision procedures," emphasizing professionalism since "professionals will generally act to protect their own autonomy," limiting oversight and other forms of political involvement, placing it within a "friendly" part of the government hierarchy, and enhancing the role of the judiciary, at the expense of more politicized aspects of the institutional structure of government (Moe 1989: 274-5).³

There is another potential problem, however, for today's winners. As Moe explains, the insulating mechanisms themselves could be overturned. How do officials overcome this problem? The answer, according to Moe, is legislation. Because of the multiplicity of veto-points in the legislative process under a separation of powers system, new laws are extremely difficult to pass—actors do not need to hold a majority to block new legislation. This means that when a group can gain enough control to overcome these barriers to legislating, they utilize this "moment in the sun" to formalize not only their mandate but also the insulation of that mandate. This is precisely why an agency's *origins* are so crucial (Moe and Caldwell

² As Moe comments, "A winning group that gains control of public authority today is in a position to design and impose whatever structure it likes—but it does not own what it creates. These structures 'belong' to whoever happens to be in authority, and tomorrow opposing interests may gain control. They would then become the temporary new 'owners,' and they would have every legal right to destroy or undermine what the first group had created...." (Moe 1991: 124). See also Horn (1995) and Rothenberg (1994).

³ Moe reiterates this point throughout his work. As he adds, "An interest group...may currently be powerful enough to bring about the creation of a new public agency with a mandate to carry out programs beneficial to the group. Yet it knows its current political power may not last and its opponents may some day be able to apply public authority toward their own ends to control, redirect and perhaps undermine the agency and its policies. The group can anticipate all this and will have strong incentives to take preventative action *ex ante*." (Moe 1990: 124).

Interestingly, this view of procedural mechanisms is complemented by the bureaucratic control literature. According to this literature, procedures can be used as a means of guaranteeing actors, congressmen in particular, ongoing control over agencies. McCubbins, Noll and Weingast, for example, comment on the effectiveness of *ex ante* control mechanisms: "Administrative procedures are another mechanism for inducing [bureaucratic] compliance. Procedural requirements affect the institutional environment in which agencies make decisions and thereby limit an agency's range of feasible policy actions" (McCubbins, Noll, and Weingast 1987, 244). Moe puts an additional spin on this argument, arguing that procedures are not only a way of controlling current bureaucratic actors, but also future political ones. In particular, the same rigidity which limits the range of actions an agency can take, also force the agency to follow original mandates irrespective of future actors' wishes.

1994).⁴ This difficulty in passing legislation means that when it can be passed, one can be relatively sure that it will remain in place for a long time. Notably, this durability of legislated insulation mechanisms can be contrasted under a separation of powers system and under a parliamentary system. As Moe and Caldwell point out, with a parliamentary system, there is unitary control, so legislation is not difficult to pass. Therefore, using legislatively-determined organizational structure as a way of cementing long-term policy is not effective in these systems. Insulation of the type found in the United States, for example, is not available in parliamentary systems.

These mechanisms by which a program or agency is insulated from future interference are not costless, however. Instead, they serve to limit the ability of the agency's creators to control 'their' agency's policies. As Moe explains:

The driving force of political uncertainty, then, causes the winning group to favor structural designs it would never favor on technical grounds alone: designs that place detailed formal restrictions on bureaucratic discretion, impose complex procedures for agency decision making, minimize opportunities for oversight, and otherwise insulate the agency from politics. The group has to protect itself and its agency from the dangers of democracy, and it does so by imposing structures that appear strange and incongruous indeed when judged by almost any reasonable standards of what an effective organization ought to look like (Moe 1990, 137).

Even though Moe's theory takes account of electoral dynamics, it does not completely explain the nature of electoral effects on agency structure and performance. Moe originated his theory as a response to the popular view among public administrationists that political and private organizations are governed by the same forces. Arguing from largely a normative perspective, public administrationists wanted public organizations to ape private ones, and therefore, theories about the effective makeup of a private organization were applied to public bureaucracies as well. Moe's primary aim was to highlight that politics indeed has an impact on the structure and performance of governmental organizations.⁵ For rhetorical

⁴ As Moe and Caldwell (1994: 9). argue, "A crucial thing to know about a separation of powers system is that it does just what the founding fathers intended: its multiple veto points ensure that making new laws is extremely difficult. The flip-side is that anything fortunate enough to *become* law is securely protected against reversal in the future. While fragile bargains and logrolls may be needed to put these initiatives over the top, once embedded in law their survival—and the durability of the deals on which they are based—is virtually guaranteed. There is no long-term commitment problem to be overcome, no delicate cooperation that needs to be sustained. Whatever is formalized will tend to endure".

⁵ As Moe explains, "A guiding principle during the formative years of public administration was a separation of politics and administration. According to this notion, a normative one about how good government ought to work, it was the job of elected officials to set public policy throughout the political process, and the job of administrators to execute policy impartially and effectively—which was possible only in

reasons, therefore, he presents his theory in relief against an argument that politics does not matter. "Yes, politics does matter," he might say, and articulate the aspects that make a difference.

For students of public organizations, however, Moe's theory requires expansion. While Moe provides a useful basis for distinguishing *between public and private organizations*, his theory cannot adequately account for variation *among government agencies*. Moe's theory ignores the possibility that the political forces he outlines—in particular compromise, fear of the state and uncertainty—are *variables*. In fact, this is almost certainly the case. Uncertainty has been much greater in the post-war United States than in Japan, for example, where the Liberal Democrats had uninterrupted political control from 1955 to 1992.⁶ Even within the United States, interest groups face differing likelihoods of gaining their "moments in the sun." Compare, for example, business versus environmental interests in the pre-War United States, to the battles between business and labor (Vogel 1989). In the former case, there was very little uncertainty—environmental interests were very rarely in control of authority. In the latter case, however, power frequently shifted between those who favored business and those who favored labor.

This fact has broad implications for Moe's informal theory. First, his rhetorical battle with the public administrationists means that he fails to address any *variation* in the structure and performance *between* public organizations. Many scholars have commented on the fact that "bureaucracy" is not a single type. As Wilson notes, "If organization matters, it is also the case that there is no one best way of organizing...[T]he variety of coordinating mechanisms is [manifold]" (Wilson 1989: 25). Moe, however, ignores this variation, instead citing both factors and outcomes as dichotomous.

Second, and perhaps more importantly, treating these elements as variables, and the decisions made by the players as strategic choices, might lead one to results much different than those presented by Moe. For example, he explains that insulating an agency against future dismemberment or even disembowelment, comes at a cost. If this cost is prohibitive, surely rational players would live with the shadow of the future, rather than completely negate the effects of their gains for the present. In treating each of his factors—the degree of

the absence of politics....In [the early political scientist's] eyes, therefore, organization theory was important for what it had to say about effective administration, which was inherently nonpolitical and no different in its fundamentals from the organization of business" (Moe 1991: 108).

uncertainty, the costs of cooperation and the costs of insulation—as dichotomous, Moe presents a single, invariant view of bureaucratic structure. Further, he "stacks the deck" in favor of such a picture in presenting his empirical examples. Moe cites two cases to illustrate the effects of political uncertainty: environmentalists and the Environmental Protection Agency, and consumers and the Consumer Product Safety Commission (Moe 1989).⁷ In both of these cases, a group that has traditionally been completely shut out is momentarily in power. Surely, given their history of powerlessness, these groups would not anticipate holding authority for long. Thus, it is likely that they would be willing to sacrifice much of their potential current benefit to "lock in" ongoing returns which otherwise would be almost certainly lost. Moe fails to examine, alternatively, what the other group would do when they are in power. Would the traditional "winner"—in these cases, big business—be willing to incur a penalty in every round?

The models presented here directly address this question. They show that both of Moe's claims—that uncertainty leads to insulation, and that this insulation is an important explanation for bureaucratic inefficiency—must be reconsidered. First, it is not the case that political uncertainty increases destructive non-cooperation. Second, while uncertainty can lead to bureaucratic inefficiency, there are limits to which such uncertainty can be used as an explanation for agency performance.

2. The Reciprocity Game

In this and the following section I develop models of structural choice that are intended to capture in a simple manner the spirit of the non-formal dynamic theory of policy insulation. The intention is to follow the original theory as closely as possible, writing down its assumptions formally to understand whether the stated results necessarily follow. To that end, the basic components of the formalization follow the central principles of that theory:

⁶ See, for example, Muramatsu and Krauss (1987); Eads and Yamamura (1987); Johnson (1982).

⁷ Notably, Moe also gives the example of the Occupational Safety and Health Administration. In this case, two relatively established groups—business and labor—fight over structural choices. This is not used, however, to illustrate the effect of uncertainty. Instead, Moe gives it as an example of political *compromise*. He gives a number of examples where the labor interests had to concede structural decisions to business—such as the creation of the National Institute for Occupational Safety and Health—which ultimately crippled OSHA.

the primary actors in the choice of structure *are interest groups*;⁸ *structural choices are “inefficient”*, meaning insulation reduces the value of the policy to the implementing group, and conversely that there can be *gains from avoiding these costs*; that play is *dynamic*, so that groups are long-lived and benefits, costs, and indeed, strategies are forward-looking; and that *uncertainty* is inherent to political outcomes.

The first game is an infinite repetition of a two-player interest-group game. Following Calvert (1989), I call this the *reciprocity game (RG)*. It is presented in its extensive form in Figure 1. In each period t , a non-strategic player called Nature selects either A or B to move. The probability that A is selected in any stage is $\gamma \in (0,1)$. A substantive interpretation for γ is the probability of A being elected, while $1 - \gamma$ is the probability of B being elected. Under this interpretation, the degree of *political uncertainty* increases as γ approaches 0.5. As γ moves towards either of its bounds, a particular group's reelection chances become more and more certain.⁹

DEFINITION 1. *Political uncertainty is decreasing in $|\gamma - 0.5|$.*

⁸ It is important to note that in an attempt to be true to the theory, and for analytical simplification, I reduce the game to one in which the players are represented to be *interest groups* vying for control over public authority. In fact, this is a close approximation to Moe's own view of legislative struggles over the politics of structure. As Moe (1989, 281) comments, “Generally speaking, groups on both sides will find Congress a comfortable place in which to do business. Legislators are not bound by any overarching notion of what the bureaucracy as a whole ought to look like. They are not intrinsically motivated by effectiveness or efficiency or coordination or management or any other design criteria that might limit the kind of bureaucracy they are willing to create. They do not even want to retain political control for themselves. The key thing about Congress is that it is open and responsive to what the groups want. It willing builds, piece by piece—however grotesque the pieces, however inconsistent with one another—the kind of bureaucracy interest groups incrementally demand in their structural battles over time.” The caveat Moe puts on this interest group oriented approach is an important one: the president is usually not so beholden to any interest group. In this sense, divided control over institutions might not be strictly an interest group game. This concern should be tempered in two ways. First, even if outcomes are a convex combination of the groups' preferences as reflected through Congress and the president, then competing for Congressional authority is still determinative of outcomes. Second, and perhaps more importantly, I also show that the basic comparative statics results of the model in this section apply under conditions of highly divided control over public authority, implying that the basic intuitions would hold with an alternative conception of interest group and institutional interactions.

⁹ Notably, the assessment of the results below depends critically on Definition 1. If one was to read Moe and his colleagues' definition of uncertainty differently—as increasing as a group's chances of winning a particular election decrease—then the results below clarify such a definition and confirm the intuitions that follow from it. In the following pages, however, I choose an alternative reading of their work, in which uncertainty is defined as in Definition 1.

the stage are (β, β) .¹³ Therefore, if a player chooses *NO* when given the opportunity, he is accepting a loss of $1-\beta$ in that iteration. Notably, this construction of payoffs is extremely flexible. For example, if $\beta = 0.5$, then choosing *NO* means that a player splits the available benefits with the other player. Alternatively, if $\beta > 0.5$, then choosing *NO* is welfare-improving, since the total benefits are greater than 1, which is obtained when a player chooses *O*.

A player's payoff is the sum of these stage payoffs, discounted by a factor $\delta \in (0, 1)$ for each successive stage. Thus, the payoffs for each player can be calculated as

$$U_{it} = \sum_{t=0}^{\infty} \delta^t u_{it} \quad i = \{A, B\} \tag{1}$$

A player's *strategy* describes what a player will do given all possible histories H_t of the game to that point. Thus, player i 's strategy is a function s_i which in *each stage* maps all possible histories into a *choice* $\{O, NO\}$. In particular, a player's strategy in turn T depends on $N^T = (n_1, n_2, \dots, n_T)$ which is a record of the random selections made by Nature in each turn t to that point, $A_A^T = (A_{A1}, A_{A2}, \dots, A_{A(T-1)})$ and $A_B^T = (A_{B1}, A_{B2}, \dots, A_{B(T-1)})$.¹⁴ Further, I assume that in all stages there is *complete information*. In other words, players know the structure of the game (including the parameter values represented by the triple (δ, β, γ)), the history of the game to that point h_t , and the strategy being played by the other player.

In infinitely repeated games, there invariably exist a multiplicity of equilibria. A number of "folk" theorems have demonstrated that, given sufficiently patient players, every feasible payoff set that is individually rational can be supported as a Nash equilibrium.¹⁵ To analyze these types of games, therefore, one conventionally posits a set of equilibrium

¹³ The assumption of equal payoffs to both sides is important in establishing Proposition 2 that follows. This assumption in some sense is employed for two reasons. First, in some situations, such "splitting of the benefits" will obtain in practice. Second, even if one assumes that the payoffs are not the same for the winner and the loser, as long as there are benefits to cooperation, the results in Proposition 2 will remain substantively the same, as will be shown in the case of spatial utility functions.

¹⁴ For clarification,

$$n_t \in \{A, B\}$$

$$A_{it} = \begin{cases} \emptyset & \text{if } i \neq n_t \\ \{O, NO\} & \text{otherwise} \end{cases}$$

So, let $h_t = n_t \times A_{At} \times A_{Bt}$ and $H_t = \{h_1, h_2, \dots, h_{t-1}, n_t\}$, then for period t , $s_{it}: H_t \rightarrow \{O, NO\}$.

strategies for the players, and then determines under what subsets of the parameters of the game such strategies can be supported as an equilibrium. To obtain these conditions, one cannot rely on backwards induction since there are an infinite number of iterations of the stage game. Instead, one must state the expected payoffs to playing a particular strategy, and identify the conditions under which playing such a strategy is a best response given the other player's equilibrium strategy.

For the purposes here, we are particularly interested in the conditions under which cooperation can be sustained as an equilibrium. Cooperative equilibria are defined as those in which, on the equilibrium path, both players choose *NO* in every stage. In general, in repeated games in which discounting is not too extreme, there exist strategies which can result in sustained cooperation (Bendor and Mookherjee 1987). Following the solution concept outlined above, we consider the parameter space under which cooperative equilibria can be sustained for a punishment strategy commonly referred to as *grim trigger*. Under grim trigger, the players will cooperate only as long as the other player has always cooperated.

DEFINITION 2. *A player i plays a **grim trigger strategy** if in each stage, he plays *NO* if the other player has played *NO* in every turn previously. If the other player has ever played *O*, then i plays *O* for every turn thereafter, given the opportunity.*

We present the analysis of equilibria under grim trigger for two reasons. First, grim trigger is a particularly suitable strategy to analyze for repeated games of complete information such as *RG*. The reason is that with perfect information, grim trigger is the most extreme form of punishment which is still subgame perfect (Bianco and Bates 1990). That it is subgame perfect with complete information is straightforward: the punishment strategies are, for the *RG*, simply Nash-reversion strategies, which means that they are subgame perfect off the equilibrium path (Morrow 1994, 266).¹⁶ In this sense, grim trigger is a *test case*, a

¹⁵ See, for example, Theorems 5.1 and 5.2 in Fudenberg and Tirole (1991), Chapter 5.

¹⁶ Further, an analog of the Fudenberg and Levine theorem applies in this case. This theorem states that if the stage game in an infinitely repeated game has a finite number of pure actions, there exists a worst subgame perfect equilibrium for each player. In this case, there are both a finite number of actions and, given an appropriate β , actually pulling the trigger is the minimax outcome, so a grim trigger strategy is subgame perfect (Fudenberg and Tirole (1991), 161).

necessary condition, for cooperation to be a Nash equilibrium. If cooperation cannot be sustained under a grim trigger punishment strategy, it is unsustainable under any feasible strategy. Second, it is reasonable to assume that in practice, players will not play such extreme strategies. However, as shown in the Appendix, the results that follow in Propositions 1 and 2 hold for any finite period punishment phase. In other words, even if players punish deviators only for a few periods, the results will be qualitatively the same.¹⁷ We present the grim trigger results here for continuity of analysis with the insulation game which follows. In the *IG*, finite period punishment strategies do not yield closed-formed solutions.

Given this approach, it is possible to characterize the nature of cooperative equilibria in the *RG*.

PROPOSITION 1. *Given δ and γ , if β is sufficiently high, cooperation can be sustained.*

Proposition 1 demonstrates that under certain conditions, it is possible to sustain cooperation.¹⁸ In interest group or party competition, there are a number of possible reasons β

¹⁷ As mentioned, we use the solution concept of *subgame perfection*. A number of game theorists argue that a more appropriate solution for repeated games of this nature concept is *renegotiation proofness*. The basic concern about subgame perfection is that even if players are playing optimal responses to other players' strategies, it might be the case that *following* a deviation, the punisher will have an incentive to go back to playing the original equilibrium; if players can confer about their strategies during play, it will be in the punisher's interest to at least try a renegotiation. For this reason, Fudenberg and Maskin introduce a concept of renegotiation proofness, in which players have no incentive to deviate from the punishment path. In general, however, grim trigger will not satisfy renegotiation proofness. In the Appendix, I construct an alternative set of strategies which are renegotiation proof: players execute finite punishment periods in which the deviator participates in the punishment. Under these more complex strategies, Propositions 1 and 2 remain substantively the same (Fudenberg and Tirole (1991), Chapter 5).

¹⁸ An interesting aside to this result is that the cooperative space obtains for a pair (δ, γ) only if $\beta > \frac{1}{2}$. This means that for cooperation to be an equilibrium in the *RG*, the sum of the payoffs under cooperation must be greater than the sum of the payoffs under non-cooperation (which is 1). If on the other hand cooperation yields results in which the total utility for both payers is *weakly less than* that available in the noncooperative outcome, cooperation *cannot* be sustained. To see this, suppose $\beta < \frac{1}{2}$ and that conditions (4a) and (4b) hold.

This implies that

$$1 - \delta + \delta\gamma + 1 - \delta\gamma < 1 \Rightarrow 2 - \delta < 1 \Rightarrow \delta > 1$$

which contradicts the assumption that $\delta \in (0, 1)$. This means, similarly, that in the *RG* cooperation could not be obtained if the stage payoffs were modified to be zero-sum (i.e. one player gets β and the other $1 - \beta$ in a cooperative phase).

might be sufficiently high. If groups value *policy continuity*, there will be a payoff to cooperation. Groups could value continuity for one of two reasons: first, groups could be *risk averse*; second, policies could be more effective with lower *policy volatility*. Another reason β could be large is that much political bargaining takes place across more than one dimension. If the players care differently about the two dimensions, if their indifference curves over the policy space are *elliptical*, then compromise positions will yield benefits. For pork barrel politics, groups often value pork in their home districts more than they care about the costs of such projects in other districts. In the context of agencies, often times policies are distributed across more than one agency, with groups caring differently about the policies carried out by the two agencies.

That cooperation can be sustained is perhaps not very surprising, since it has been shown in a number of different repeated play games that as long as the penalties for cooperation are not too stiff (here expressed as a sufficiently high β), and the players value the future sufficiently (in other words if δ is sufficiently high), cooperation can be sustained.¹⁹ Proposition 1, however, allows us to explore the relationship between political uncertainty and cooperation. Namely, I can further extend this result to obtain *comparative statics* concerning the relationship between uncertainty and cooperation.

PROPOSITION 2. *As γ approaches 0.5, cooperation can be sustained over a wider range of the parameters.*

¹⁹ Proposition 1 also allows us to consider the *source* of cooperation: does cooperation derive from uncertainty or from competition between players? To answer this question, an example is instructive. Consider two possibilities: the first is the *RG* in which $\gamma = 0.5$; the second is a different game in which players alternate control over public authority *with certainty*. While in both games there is competition between programs and the expected number of turns to be in power over any T turns is $T/2$, in the first case there is uncertainty, while in the second there is none.

To compare these two cases, note first that with $\gamma = 0.5$, $\beta^* = \frac{2-\delta}{2}$ in the *RG*, which I will call β_U^* .

Alternatively, for the hypothesized game without uncertainty, it is straightforward to show that $\beta^* = \frac{1}{1+\delta}$, which I will call β_{NU}^* . If we compare these two cut-points, we obtain that $\beta_U^* > \beta_{NU}^*$ since

$$\frac{2-\delta}{2} > \frac{1}{1+\delta} \Rightarrow (2-\delta)(1+\delta) - 2 > 0 \Rightarrow \delta(\delta-1) < 0$$

which follows by assumption. This result illustrates that cooperation is *easier* to sustain without uncertainty, even if the expected number of turns in power is the same under an uncertain and certain regime. The intuition behind this result is that in the uncertain case, punishment strategies are less forceful, since there exist potential

Proposition 2 contains a surprising result: as political uncertainty *increases*, reciprocity is *easier to sustain*.²⁰ This is an interesting result for at least three reasons. First, it is distinct from the many results concerning discount factors in infinitely repeated games. In particular,

Figure 2.2. Illustrative Equilibria of Reciprocity Game

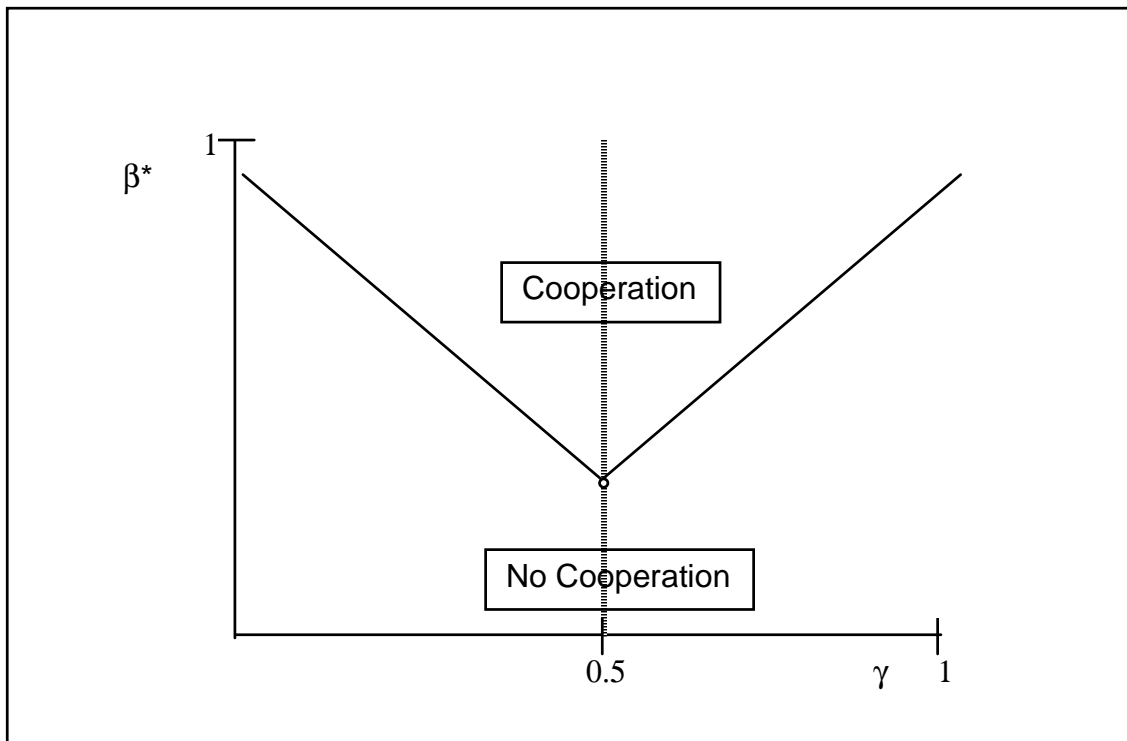

outcomes in which a defector will not be punished for an arbitrary t turns. Alternatively, in the certain case, the defector knows with certainty that he will be punished immediately, and so the benefit of defection is reduced.

²⁰ It is interesting to compare these results to those of Calvert. Propositions 1 and 2, with a few caveats, can be considered refinements of Calvert's model. His model provides a similar analysis of the effects of random recognition on reciprocity. He considers a case in which the probability of one group (say A) asking for a favor is extremely small, while the probability of the other group (say B) asking for a favor is very large (which would correspond to $\gamma \rightarrow 1$ or $\gamma \rightarrow 0$ in the RG). He finds that in this case, the ratio of A's costs for giving a favor and benefits for receiving one must be "tiny" for reciprocity to obtain. In other words, if the players are playing grim trigger and uncertainty is low, reciprocity can be sustained only for a small set of the parameters. This result conforms with the intuition behind Propositions 1 and 2. It is worth noting, however, that the structure under which these results are obtained has an important difference from my results. Whereas in Calvert's model the probabilities of the two players' offering cooperative favors are *independent*, in the RG they are *dependent* (specifically, if one player has a probability γ of winning, then the other has $1-\gamma$). It is this dependence between the probability of having an opportunity (in Calvert's terminology) which generates the parabolic nature of the cooperative parameter space in the RG. Further, although not critical to his result, Calvert's players move simultaneously, whereas control in the RG is exclusive to a single player in any stage t , which more closely conforms to a situation in which there is direct competition for public authority. These refinements are important to truly understand the nature of insulation decisions examined later in the paper. (Calvert, 270-273, 276-279)

there are a number of folk theorems which state that as the discount factor increases, as the players place a greater value on future opportunities, cooperation can be sustained over a wider range of the parameter values.²¹ This is not the case with the parameter γ . As shown in Figure 2, the parameter values over which we get cooperative reciprocity is not monotonically increasing in γ . Instead, the cooperative space is parabolic, with a vertex at one-half. Notably, the source of this pattern is the complementary nature of the reelection parameter. Since *both* players must choose *NO* for a cooperative outcome to be achieved under grim trigger strategies, and an increase in one player's reelection chances implies a decrease in the other's, as γ moves towards its extreme values, an increased propensity to cooperate by one player is complemented by a decrease in the other player's likelihood of cooperating. Thus, it is as reelection probabilities jointly move toward the middle values, the parameter space for cooperation increases.

A second reason this result is interesting is that it is counter to Moe's claim. According to Moe, political uncertainty means that today's winners will be tomorrow's losers. Because of this, today's winners are more vulnerable as uncertainty increases. Proposition 2, however, illuminates this claim. While it is true that increasing uncertainty about retaining political power gives opponents greater opportunities to undo what a currently prevailing group implements, because of the *repeated* nature of the interaction, uncertainty also gives players a greater payoff for cooperating. Thus, as long as the penalties for cooperation are not prohibitive, uncertainty provides incentives for constructive rather than the collaterally destructive behavior Moe posits. More generally even, the intuition is quite powerful: in a democratic institutional structure, repeated play in itself is not sufficient to sustain cooperation. Instead, it is precisely the possibility of losing power which *enables* players to employ punishment strategies which can effectively engender cooperative outcomes. Thus, beyond the domain of agencies, the *RG* provides conditions under which stable, cooperative democratic institutions can be maintained.

Further, the *RG* and the result from Proposition 2 is particularly suited to explaining cooperation in systems where there is unitary control of both the executive and legislative

²¹ See, for example, Fudenberg and Tirole (1991), Theorems 5.1, 5.2, and 5.6; Kreps (1992), Appendix A.

branches, such as a parliamentary system. As noted by Moe and Caldwell, in these systems, in contrast to presidential systems in which control is divided, legislation is not difficult to pass for those who hold public authority. What this means is that legislating insulated agency structures will not tie the hands of those that follow: the legislation which is designed to insulate can be overturned itself by future holders of public authority. This is precisely the situation described by the *RG*, in which the players do not have an option to insulate. In this sense, the *RG* illuminates the nature of dynamic cooperation between groups in a parliamentary, not presidential, system: when there is no dominant group, cooperation will be more prevalent (Moe and Caldwell 1994). In this case, the *RG* provides a very general result for political activity. In situations in which there is electoral balance, cooperative, and perhaps even moderate, outcomes will be most likely to obtain.

Before proceeding to considering the effects of insulation strategies, it is useful to consider the generality of these results. One important issue is that in many cases, indeed those described by Moe, competition is on a single-dimension—the history of labor, environment and consumer protection, for example, all might described this way. This raises a question as to whether the results will still hold where policy competition is so direct. In fact, as long as the players exhibit sufficient aversion to risk, the results in Propositions 1 and 2 will hold (these results are proved formally in the Appendix). Indeed, the degree of “cooperative benefit” represented by β could be interpreted in the traditional setting of negative quadratic spatial preferences in a uni-dimensional policy space. To see this, consider the following modification to the players’ utility functions. Here, when a player holds control over public authority, she must pick a policy in a policy space $x \in X \equiv \Re$. Players have normal quadratic stage game payoffs represented by a utility function $u_i = -(x - x_i)^2$ $i \in \{A, B\}$ where, without loss of generality, the players’ ideal points are $x_A = 0$ and $x_B > 0$. In this case, given the parameters of the model, players will have a region in X over which they will be willing to cooperate in equilibrium. Specifically, A will cooperate if the B cooperates and if $x \in \{-x_B\sqrt{\delta(1-\gamma)}, x_B\sqrt{\delta(1-\gamma)}\}$. Similarly, B will cooperate if A cooperates and $x \in \{x_B(1-\sqrt{\delta\gamma}), x_B(1+\sqrt{\delta\gamma})\}$. Since cooperative equilibria require both sides to cooperate, then cooperative equilibria will exist only if there is an intersection in these two regions. In other words, if the highest policy A would accept in a cooperative equilibrium is higher than the

lowest policy B would accept in a cooperative equilibrium (i.e. if

$x_B \sqrt{\delta(1-\gamma)} \geq x_B(1-\sqrt{\delta\gamma})$), then cooperation can occur. Further, a closer examination of these bounds also shows that the size of these bounds is *increasing* as the electoral probability of A moves to 0.5. Thus, using the traditional formulation, and even if conflict is one-dimensional, Proposition 2 also holds. This solution shows that negative quadratic utility functions in a uni-dimensional policy space is simply a special case of the model presented above.

A second extension which provides an indication of the generality of the results is considering a case when control over public authority can be divided.²² In this case, we extend the model to analyze a case in which there are a set of n institutions. In this case, for simplicity, we assume that for a policy to be changed requires control of the full set of institutions, or undivided control over public authority. We continue to assume that the two groups have a probability of controlling any single institution which is the same as before. Although a strong assumption, to provide an intuition, we will assume that the probabilities of holding authority over any one of the institutions is independent across n .²³ In this case, again the parameter space for which cooperative equilibria is the largest is when political uncertainty is maximal (a formal proof of this point is presented in the Appendix). The intuition behind the logic of this result is the following. The payoffs to cooperation for both A and B are the same as in the earlier formulation with a single institution. To calculate the payoffs off the equilibrium path, we must first calculate the probabilities of three possible states: that there is undivided control for A , which occurs with probability γ^n ; undivided control for B , which occurs with probability $(1-\gamma)^n$; or control is split which occurs with probability $1-\gamma^n-(1-\gamma)^n$. Here, the incumbent's policy, the last policy emerging from undivided control, is retained with a higher probability than in the previous formulation. For example, if A 's policy is the status quo, then the likelihood that A will be the policy in the

²² In this sense, I follow recent scholarship which emphasizes that overturning policy is difficult when there are multiple veto players (Moe 1989; see also Tsebelis 1995, Krehbiel 1998, Brady and Volden 1998).

²³ In fact, if we think of this situation as being control over institutions in a separation of powers system, it is reasonable to assume that perhaps results of elections are correlated across institutions (e.g. if a party wins the presidency it affects its probability of winning each of the houses of Congress). While introducing such correlation is a straightforward adaptation of the model developed here, it complicates the exposition without

following period is the probability that A obtains undivided control *or* control is divided, or $1 - (1 - \gamma)^n$. However, if B 's policy is the status quo, then the probability A 's program will be implemented is *only* the probability that A gains undivided control or γ^n , which is smaller. In this sense, policy implementation under separation of powers exhibits “stickiness.” Further this stickiness of the institutions advantages the stronger player: whoever is more likely to control the institutions on average will have their program in place for an even longer time than in the game with only singular institutions. Loosely, this implies that the stronger player will have an even weaker incentive to comply with any cooperative equilibrium. This has a number of important implications. First, cooperation will be harder to obtain, the minimum β will be weakly higher, when the possibility of divided government. Second, as before, these incentives are dulled when competition is relatively even. The intuition is similar: as we saw in Proposition 2 above, when a player is extremely strong, she has little incentive to cooperate. With the addition of institutional stickiness, this becomes magnified, meaning with even smaller increases in the stronger player's electoral chances, the parameter space for cooperation shrinks. In the reverse, however, as the players become more equal, the incremental effect goes down, making cooperation easier to sustain, as Proposition 2 states. Thus, despite the change in the *level* of gains from trade required to obtain cooperation, the comparative statics *within* the institutional structure, that cooperation is easiest to sustain when electoral chances are even, remain the same.

3. The Insulation Game

The results in Propositions 1 and 2 are important to our understanding of bureaucratic structure. In particular, if repeated play means that strong incentives exist for cooperation rather than sabotage, the view that bureaucratic structure and inefficiency are born from political uncertainty must be called into question. But while these results provide a general context for an analysis of uncertainty in politics, a more nuanced study is required to truly explicate the effects of electoral ambiguity on agency structure.

substantively changing the results. Indeed, as will be shown, since the probability of controlling all n institutions is a function of γ , the results from Proposition 2 will hold under any assumption of correlation.

In particular, Moe explains that overturn and sabotage are not the only recourse to political groups. Indeed, through the use of organization structure, groups can actually waylay such sabotage attempts. According to Moe, "today's winners" given their place in the sun, will use devices such as legislated structural requirements, thick procedural guidelines, and statutory standards to *insulate* an agency from future interference.

Moe's description points to a further refinement to the *RG*. We therefore introduce the Insulation Game (*IG*), which reflects a group's ability to insulate an agency from sabotage. The structure of the *IG* is similar to the *RG*. As with the *RG*, the game is between two players, *A* and *B*, and is repeated indefinitely. Also, as previously, players implement their proposals with certainty, and, if the other player's program is in place, the moving player has the option of either overturning (*O*) or not overturning (*NO*). In addition to this structure, there is an additional strategic choice the players must make: whether to insulate their agency or not. Thus, when implementing her program, each player must choose from the action set $A_i' = \{\text{insulate; not insulate}\}$, where we denote insulate by *I* and not insulate by *NI*. Further, to capture the notion that this opportunity is available only rarely, a player makes this decision only during the *first* period in which she is recognized. The extensive form of the *IG* is shown in Figure 3.

In each stage, if a player plays *NI*, then her payoffs are identical to those in the *RG*. However, if a player chooses *I*, his payoffs are modified by a factor α which is strictly less than 1 ($\alpha < 1$). The benefit to the player of playing *I* is that, irrespective of the other players' play from $\{O; NO\}$, the insulating player's program remains in place forever.²⁴ Thus, if the other player's program is in place, the insulating player receives $\alpha\beta$; otherwise, he receives α (which, by construction is greater than $\alpha\beta$). In the process of formalization, then, we are able to define more precisely what policy "insulation" means. Specifically, we can think of

²⁴ I use the assumption of permanent insulation to simplify the exposition. An alternative assumption, that insulation survives for a discrete number of periods, leads to substantively similar results.

Figure 2.3. Extensive Form of Insulation Game (IG)

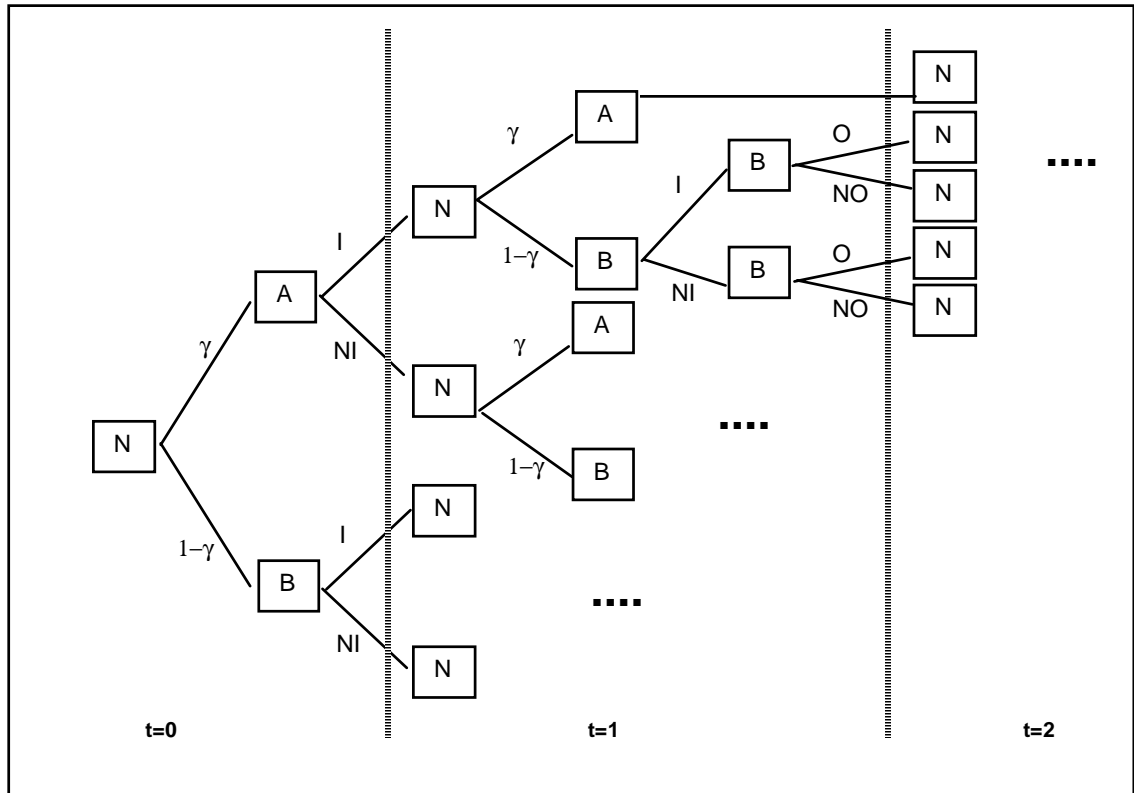

insulation in the context of the *RG* in either of two equally valid ways. On the one hand, insulation is a mechanism whereby groups or officials can *avoid punishment strategies*. Since insulation locks in benefits, groups can act destructively without fear of retribution. On the other hand, insulation mechanisms are those that *trade benefits when in power for benefits when out of power*; groups can *smooth* their benefits. This construction allows us to interrogate the conditions under which an agency will be insulated, and those under which it will not be. In particular Propositions 3a, 3b, and 3c, characterize equilibrium strategies and outcomes as the cost of insulation, parameterized by α , varies.²⁵

PROPOSITION 3a. *If α is sufficiently large, both players will play $\{(I,O)\}$.*

²⁵ For the *IG*, the strategy which we analyze is a modified version of *grim trigger*. The insulation choice is only an element of the action set at the player’s first period of recognition. Regardless of the player’s strategy at that node, his strategy is to play grim trigger with respect to the overturn-not overturn choice in every turn he is recognized.

PROPOSITION 3b. *If α is not sufficiently large for both players to play $\{(I,O)\}$, then an equilibrium for the IG is either $\{(I,O);(NI,O)\}$ or $\{(NI,O);(I,O)\}$ if α is sufficiently large.*

PROPOSITION 3c. *If α is sufficiently small, then neither player will insulate.*

Propositions 3a through 3c provide insight into the employment of insulation mechanisms to protect agencies and programs against potential future sabotage, based on the cost of insulation.²⁶ A significant penalty for insulation will induce a group to leave their agency unprotected. This is consistent with intuition, but also provides a much greater understanding of the behavior of competing groups. Moe argues that the shadow of future competition forces groups to insulate, and therefore, crippling agencies by design. However, the results from the *IG* indicate that Moe's story is incomplete: only if the cost is relatively minor, will agencies be insulated. If the cost is moderate, then, *depending on the reelection potential of the group*, only one group will choose to insulate. And if the cost is prohibitive, neither agency will insulate, and the behavior will either be cooperative or destructive, depending on the cost of cooperation, a result seen earlier in the *RG*.

While Propositions 3a, 3b and 3c, provide a picture of how the equilibrium varies in relation to the cost of insulation, the primary question is the relationship between political uncertainty, reflected by the parameter γ , and the decision to insulate. According to Moe, it is the fact of uncertainty that causes groups to insulate. In fact, as shown in Proposition 4, electoral uncertainty *interacts* with the cost of insulation to determine equilibrium behavior.

PROPOSITION 4. *Under the conditions given in Propositions 3a through 3c, as political uncertainty increases, the parameter space over which either both players insulate and neither player insulates increases, while the parameter space for which a single player insulates decreases.*

²⁶ Indeed, although Propositions 3a through 3c give a picture of some of the equilibrium, because of both the range of possible parameter values, the infinite and repeated form, and the nature of the interactions, they do not show uniqueness. Despite this (common) problem, they do allow a characterization of equilibrium behavior under fairly general conditions.

When combined with Propositions 3a through 3c, Proposition 4 provides a richer understanding of the nature of insulating mechanisms as a structural choice.²⁷ Under fairly general conditions, we can characterize an equilibrium for the *IG*. As shown in Figure 4, the

Figure 2.4. Illustrative Equilibria of Insulation Game

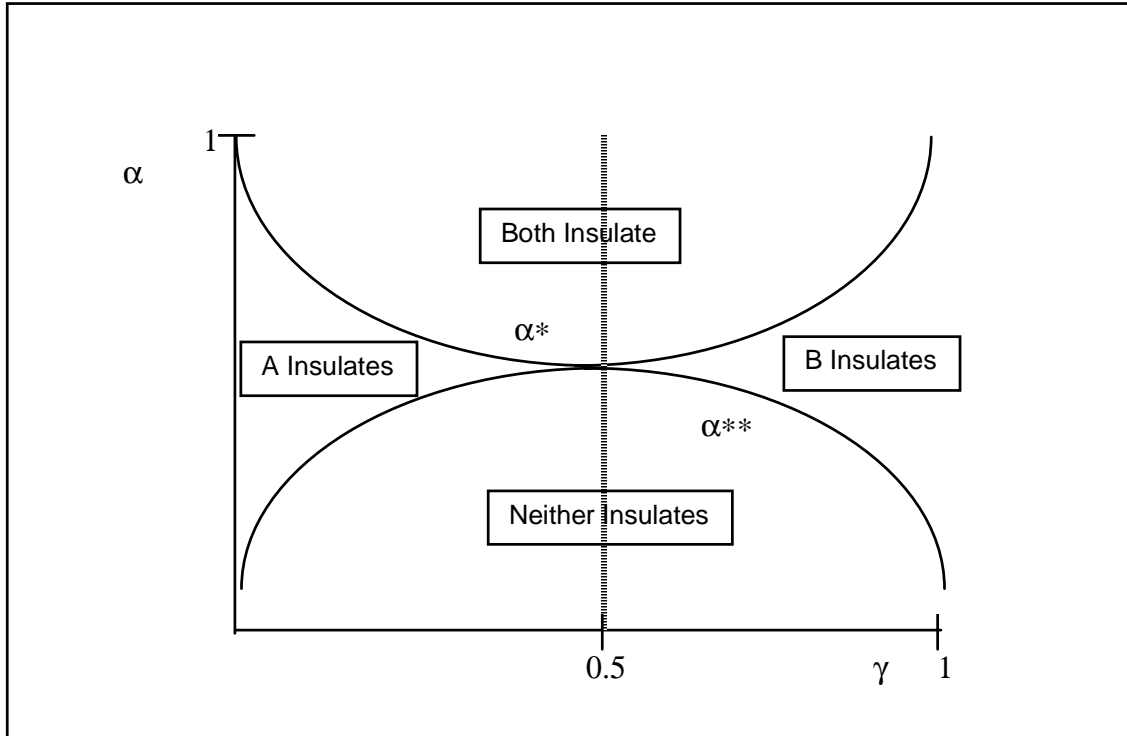

equilibrium will depend on a combination of both the costs of insulation and the probability of reelection. In particular, as the costs of insulation increase (as α decreases), only those with a very small chance of being elected will insulate. Thus, they ensure they get some benefits on an ongoing basis, and the regularity of those benefits is an incentive which outweighs the cost incurred by overburdening an agency with procedures.

The relationship to political uncertainty can be characterized in two ways. First, for comparing public and private organizations, the proposition confirms Moe's primary claim: public organizations will be weakly less effective than private ones. To see this, compare the "first best" situation of a public organization operating with no electoral uncertainty to one in

²⁷ For the purposes of illustration, we describe a particular equilibrium here and in Figure 4, which assumes that the triple (δ, β, γ) are such that $\alpha_A^{**} < \alpha_B^*$ when $\gamma < 0.5$, and that $\alpha_B^{**} < \alpha_A^*$ when $\gamma > 0.5$.

which uncertainty exists. In the former case, inefficient insulation will never be employed. In the latter case, uncertainty makes groups more likely to employ insulation mechanisms. Second, as political uncertainty decreases, a wider space of parameters will support one of the groups (that which is most commonly out of power) deciding to insulate. However, as political uncertainty *increases*, a larger set of values of α will support both insulating. As Proposition 4 shows (and is illustrated in Figure 4), a larger set of values of α will also support a non-insulation equilibrium as uncertainty increases. Thus, as political uncertainty increases, a wider set of the parameter values support the extreme cases of either both insulating or not insulating. While Moe is accurate, in part, that political uncertainty increases the space over which both sides will insulate, Proposition 4 demonstrates that this is an incomplete view: increasing uncertainty *also* increases the space over which *neither* will insulate.²⁸

More importantly, Proposition 4 indicates that to explain variation among agencies, focussing on uncertainty is inappropriate. Instead, situations in which there is *electoral asymmetries* are those where insulation is most likely. Moreover, we can make a more precise statement: groups that are *electorally weak* will be the most likely to insulate. The decision to insulate is decreasing monotonically in the electoral power of a group.

This prediction has an important concomitant implication. In situations in which group power is unbalanced, the policies of the weaker group will be less effectively implemented than those of the dominant group. Since only the weaker groups will insulate their policies, only their policies will bear the costs of inefficiency that go with such insulation. In this sense, the relative value and competence of the weaker groups will be *self-confirming*: when they get their moment in the sun, they are not able to implement their policies as effectively as the stronger groups, perhaps justifying weak groups' weakness.

The *IG* also illuminates another aspect of agency performance: the degree to which political uncertainty will lead to inefficient agencies. According to Moe, along with political compromise, uncertainty leads to a general condition for bureaucracy: they are "designed to be inefficient." Propositions 3 and 4, however, clarify this claim in a number of ways. First, they establish a *lower bound* on how inefficient agencies will be due to political uncertainty.

²⁸ Note that these results broadly hold for zero-sum games as well. The proofs of all these results for a zero-sum game can be found in the Appendix.

If the costs of insulation in terms of program performance are high, groups will choose not to insulate their programs. Second, only groups that have very weak future electoral prospects will insulate. This means that when the usual winners erect agencies, they will not be hampered by such organizational designs. Assuming that the distribution of agency creation is spread evenly across time, this implies that *most* agencies will in fact be uninsulated and therefore inefficiency cannot be attributed to political uncertainty in most cases.

4. Empirical Examples

Reciprocity in the face of electoral uncertainty is a commonly observed phenomenon. While a deep empirical analysis is beyond the scope of this paper, a few stylized examples are instructive. As noted earlier, the work of Moe (1989, 1990, 1991) and others (e.g. Horn 1995) provides consistent evidence that groups with a tenuous hold on public authority, such as environmentalists and consumers, will saddle government agencies and the policy implementation apparatus with mechanisms which at once reduce the agency's ability to carry out its mandate, but also protect it from future interference. The models, above, however, provide a more general understanding of the politics of structural choice. In the rest of this section, therefore, I describe two examples which strongly illustrate the results from the above models and supplement the previous analysis: early broadcast radio regulation and the origins of the Federal Radio Commission (FRC) and later the Federal Communications Commission (FCC), and the development of institutions of United States trade policy.

Broadcast Radio Regulation. The origins of radio regulation presents a different set of political conditions to the cases of environmental and consumer product regulation. The main difference in the political environment was that in this case, regulation was being pushed for by the dominant coalition, with very little opposition. In this context, an administrative structure was erected which was much less constrained but also much more subject to future interference.

Broadly speaking, the two major pieces of legislation which created a formal administrative apparatus for radio regulation were the 1927 Radio Act, which created the FRC and the 1934 Communications Act which created the FCC, folding the FRC into the new agency. Prior to 1927, federal policy toward radio frequency regulation was governed by

a series of legislative acts—the 1887 Interstate Commerce Act, 1910 Mann-Elkins Amendments to the Interstate Commerce Act, 1910 Wireless Ship Act and 1912 Radio Act—that were designed for the management of commercial shipping frequencies and not commercial broadcasting. The latter did not emerge as a viable economic business until after World War I.²⁹ With the emergence of broadcast radio, the courts began to rule against the applicability of previous legislation to management of the broadcast frequencies. In a series of court and executive decisions, it became increasingly clear that extant statutes would not be sufficient to manage the new technology.³⁰

This gap in the regulatory framework created a strong alignment of interests in the mid-1920's behind the erection of an agency to manage radio frequencies. The relatively unopposed coalition was led by existing or aspiring broadcasters, who saw regulation as a boon in two senses: on the one hand, it was sorely needed to eliminate negative externalities from congestion and lack of coordination; second, it provided stations with a way to maintain a strong position in growing and potentially competitive markets. These broadcasters who were demanding regulation had little to fear from opponents in the future, both in the short and long-term. On the one hand, in the short term, the growing disorganization of the industry, with no coordination, meant that all segments of interests were clamoring for the government to step in and more actively organize the use of the airwaves: the nascent broadcasters, listeners, religious groups, content providers and commercial radio operators all had a common and intense interest in limiting congestion, interference and a lack of coordination. As Wollenberg (1989: 62) notes, “[In 1927,] virtually all interested segments of the public, notably including the broadcast industry, sought legislation as reflected in the

²⁹ Wollenberg (1989, 62) reports that at the beginning of 1919, there were no broadcast radio stations. By 1922 there were five hundred sixty four.

³⁰ Immediately following the passage of the 1912 act, for example, the Attorney General opined that the executive could not *manage* licenses under the act; instead it must issue to all falling within the aegis of the act. In the 1923 Court of Appeals decision in *Hoover v Intercity Radio*, the court ruled that under the 1912 Radio Act, the Secretary of Commerce—at the time, Herbert Hoover—did not have discretion to withhold licenses, effectively eliminating the ability of the government to manage the common pool congestion problem or to coordinate the allocation of frequencies. This decision was further strengthened by a 1926 District Court ruling in *United States v Zenith Corporation*, where it was ruled that the Secretary could not promulgate any rules under the aegis of the Act. After *Zenith*, the Secretary essentially withdrew from involvement, setting up a bureau in the department strictly to act as a registration and recording service with no administrative authority. (Emery 1971, Wollenberg 1989, McMahon 1979)

recommunications of the fourth radio conference in 1925.”³¹ Indeed, unlike in some other regulatory domains, their interest extended to common views on the exact nature of the policy: because the economic impact on individual consumers of broadcast regulation was indirect—since the stations did not charge for their use—most of the policy proposals which limited competition—licensing, content regulation, operational standards—were supported by the public and the broadcasters.³² Second, even in the future, consumer interests were unlikely to play much role, as they were largely unorganized. Alternatively, the broadcast industry, as it evolved, was very quickly extremely organized, with the National Association of Broadcasters becoming an important force driving the development of legislation in the four National Radio Conferences in the 1920’s and 1930’s. In this second sense, this was a classic case of what Wilson (1989) would call “client politics” and Stigler (1972) would call “capture.” As Mahan (1982: 165-166) notes, “What the Radio Act did by justifying regulation of the radio interest in the name of the radio industry in the name of the public interest was, in essence, to identify the interests of the industry with those of the public at large, and thus, the protection of radio business interests with the protection of radio audiences.”

The lack of opposition, a situation that was likely to maintain for the foreseeable future, was reflected in the focus on efficiency rather than insulation. As noted earlier, the sincere interest in solving this problem meant that almost all parties supported removing any jurisdiction from the Interstate Commerce Commission (ICC) which was perceived as more interested in other domains and lacked sufficient focus. Given that a separate regulatory agency was to be set up, the question was how to structure its powers. This classic structural choice, however, was resolved in a way much different than the debate over the organization of the Environmental Protection Agency (EPA) or Consumer Product Safety Commission (CPSC) discussed by Moe. In this case, the agency was, in almost every area, given leeway, discretion and a very wide range of motion. Rather than giving the FRC a very specific statute to implement, in the 1927 Act, “Congress turned essentially all radio regulation over

³¹ This view was seconded by Hoover who stated, “It [radio regulation] is one of the few instances that I know of where the whole industry and country is earnestly praying for more regulation.” (cited in Krasnow 1982: 17)

³² As Robinson (1989, 11) notes, for example, the issue of content regulation, in which certain portions of programming were required for “public service” uses were not objected to by industry. This at once served as an entry barrier for the industry and served the public interest in voters’ minds. As he states, “The broadcast industry did not dissent to this imperative of public obligation; they embraced it.”

to the new agency, whose discretion was limited mainly by a new requirement that its actions serve the public interest.”³³ (Wollenberg 1989: 65; see also Emery 1971: 45-49) Indeed, specific procedures that were considered and summarily discarded highlight the nature of this debate. One issue was how to structure the Commission’s decision making authority over licenses. One possibility was to house decisions over license appeals in the full body of the agency, which would have served to lessen the impact any single commissioner might have had on the implementation of policy. Instead, however, Congress arranged that the each commissioner would have full authority over licensing decisions in five regional zones.³⁴ While this enhanced the speed and efficiency in which licenses were granted, it made it more susceptible to future appointments by potential rivals. Further, unlike the previous statutory regime, now the courts supported the broad powers granted the executive wide latitude to implement restricting and coordinating license policies.³⁵ This broad mandate meant that in the period from 1927 to 1934, there was a sea change in the implementation of radio policy, primarily by a largely unfettered Radio Commission. As Wollenberg (1989: 68) notes, “During its short existence, the Radio Commission moved strongly in the direction of making bold social judgments about who should hold licenses and why.”

The other significant piece of legislation concerning regulation of radio was the 1934 Communications Act. It was prompted by the desire to integrate regulation of all communications into a single agency. The 1927 Act had divided control over communications policy between the FRC, which regulated radio, and the ICC, which retained control over common carriage. The 1934 Act eliminated the FRC, but transferred all control over radio to the newly created FCC. The broad discretion granted to the FRC in 1927 might have been altered in 1934, with the passage of the Communications Act of 1934; in fact, with respect to radio regulation, the procedural constraints remained muted, only in some limited sense becoming more stringent.³⁶ Title III of the 1934 Act, which governed the

³³ As Wollenberg (1989: 65) continues, “The Radio Commission’s general regulatory powers under the 1927 Act were expansive, as they were intended to be given the chaotic state of radio when the law was enacted.”

³⁴ Radio Act of 1927 § 29.

³⁵ In both the *KFBK Broadcasting Association v. Federal Radio Commission* (1931) and *Trinity Methodist Church, South v. Federal Radio Commission* (1932), the District of Columbia Circuit Court upheld the FRC’s right to deny licenses. In these cases, the courts gave the FRC broad latitude to interpret and implement the public interest standard contained in the statute.

³⁶ As Krasnow (1982: 10) notes, “...the Communications Act of 1934 is fundamentally identical to the legislative charter given to the Federal Radio Commission in 1927.”

licensing of broadcast radio operators, added a number of provisions to the previous statute, but all were innocuous and did not provide much constraint on the implementation of policy.³⁷ Indeed, if anything the 1934 Act maintained the executive's discretion while expanding its reach. Under the same discretion as before, the FCC was to "have the authority to suspend the license of any operator" in addition to the authority to revoke it. (Communications Act of 1934, § 303(m)) Similarly, section 302 of the Act included additional rulemaking powers for the FCC to govern chain broadcasting, again with no constraint on the agency's interpretation or implementation except that it be in the public interest. Indeed, when this power was challenged in the courts, the Supreme Court reaffirmed the FCC's broad powers, stating, "...[Although] the Act does not explicitly say that the Commission shall have the power to deal with network practices found inimical to the public interest...Congress was acting in a field of regulation which was both new and dynamic...In the context of the developing problems to which it was directed, the Act gave the Commission not niggardly but expansive powers." (*National Broadcasting Co. v. United States* 319 US 190, 218-219 (1943)). More generally, the issue of the extent of judicial review was also debated as a potential constraint on the agency. During hearings about the Act, a number of radio broadcasters who had had their licenses revoked objected to the limited extent of review and appeal granted in the 1927 Act. (Cass 1989: 86-87; U.S. Congress, Senate Hearings: 1934, 56-57) In the end, review powers were very limited as Congress decided to limit the review powers of the courts and leave discretion to the agency. As Representative Beck commented, "I am certain it is true—that the present commission has made many mistakes, yet we are of the opinion that there would be less abuse by reason of lodging that discretion to them than there would be to some court [that discretion...]" (U.S. Congress, House Record 1932: 3683).³⁸ Further, the Act provided strong, discretionary

³⁷ As Wollenberg (1989) outlines, these three were that the FRC had to provide a public announcement and hearing when there were changes to existing licenses; limited transfers according to the same broad public interest provision for new licenses; and required construction permits to have been granted for the existing licenses. The first of these three is probably the most constraining, although the public hearings were not construed—as they are today—to be a significant restriction on the agency. The hearing did not grant standing, for example, to potential interested parties, a universal procedure governing administrative rulemaking under the Administrative Procedure Act of 1946.

³⁸ The specific language of the Act limits review by stating, "Provided however, that the review of the court shall be limited to questions of law and that findings of fact by the commission, if supported by substantial evidence, shall be conclusive unless it shall appear that the findings of the commission are arbitrary and capricious." (Communications Act of 1934) As Cass notes, "Basically the same division of review had obtained under the initial Radio Act appeals provision, well before joinder of radio and wireless regulation was

powers for enforcement, allowing for fines and penalties, in addition to revocation of licenses. Importantly the use of these powers was largely left to the FCC's discretion. According to the Act, the FCC has the power to initiate investigations "concerning which any question may arise under any provisions of the Communications Act. Following such an inquiry, the FCC is authorized to take any action within its general authority it deems appropriate." (Communications Act of 1934, , § 402) As Cass (1989, 88) comments, "Together with the specific rule-making authority granted elsewhere, this [Section 402] power constitutes a strong tool for promoting coherent regulation of communications." In the end, the main limitation on the FCC was, as with the 1927 Act, a stricture to regulate in the "public interest." This standard was broadly interpretable, and meant that the agency was granted a great degree of discretion to manage licenses and promulgate regulations. As Krasnow (1982: 19) concludes: "The flexibility inherent in this elusive public interest concept can be enormously significant to the FCC...as a means of modifying policies to meet changed conditions and to obtain special support..."

The history of early regulation of radio broadcasting is a balancing example to regulations initiated by groups that perceive themselves as enjoying only a "moment in the sun." Both in the 1927 Radio Act and further in the 1934 Communications Act, regulation was not initiated by such a constellation of interests, but by groups who did not fear loss of power in the future. The result was legislation that culminated in the 1934 Act which enabled the agency to act on its own. As Cass (1989: 90) notes, "The Commission's capacity to shape policy in a manner that responds to changing circumstances and shifting interests is further advanced by the broadly worded authority delegated to the Commission in Titles II and III and by the limited scope of judicial review available."³⁹ In this sense, the relaxed procedural and jurisdictional control was made possible precisely by absence of any fear that the agency would be captured in the future by politically opposed interests.

Trade Policy. The evolution of trade policy in the late nineteenth and early twentieth centuries, culminating in the passage of the Reciprocal Trade Agreements Act (RTAA) of

contemplated." (Cass 1989: 87) Further, as Cass (1989: 91) points out, the Act's language mean when the courts did review FCC decisions, they would be more than likely to defer to the agency: "[T]he restricted scope of review probably has made for at least a marginal increase in judicial deference, and if the statistics can be credited, the FCC has not fared badly in open court."

³⁹ Robinson (1989: 18) provides a similar assessment, "What is remarkable about the communications field is the degree of freedom permitted the agency not merely to adapt its powers to deal with new

1934, also provides a useful illustration of the mechanisms explicated in the models above. The conclusion of the *RG* is that when political uncertainty is high, cooperation is easier to sustain, and when it is low, it is likely to be unsustainable. The latter is precisely the case with tariff policy in the late nineteenth century until the 1930's. In this period, the Republicans were in control most of the time, although their control was not complete. Of the thirty congresses from 1871 to 1931, the Republicans had undivided control of both houses eighteen times, the Democrats had undivided control five times, and control was divided seven times (United States Department of Commerce, Bureau of the Census 1975: 1083). The two parties' positions on tariffs were clearly articulated: Republicans preferred protectionist policies, the Democrats wanted open domestic markets. In this case, with a low degree of political uncertainty, the two sides were unable to coordinate on a cooperative solution. Instead, each side, when it was in power, alternately reduced or increased tariffs (see Table 1). As Epstein and O'Halloran (1996: 303) describe, "...[T]ariffs changed regularly in roller-coaster fashion when a new party entered office. High tariffs were followed by low tariffs, which were succeeded by high tariffs. The tariff acts of 1883, 1890, 1894, 1897, 1912, 1922, and 1930 were passed close on the heels of federal elections, with each peak in the tariff rate associated with Republican control and each trough with Democratic control."⁴⁰ Notably, this interpretation is consistent with the analysis by Epstein and O'Halloran over roughly the same time period. They argue that to understand United States tariff policy, it is necessary to take account of partisanship. As they conclude, "More precisely, when strong parties take divergent positions on an issue, changes in the preferences of the median voter that result in a new party taking office will lead to changes in policy outcomes above and beyond those explained by changes in the median voter alone. Furthermore, parties have electoral bases built on specific groups and constituencies. These coalitions will aggregate interests in different ways, implying that policy will be biased towards the coalitional base of the party in power" (Epstein and O'Halloran 1996: 302). While Epstein and O'Halloran demonstrate that partisan regime change is an important determinant of changes in tariff policy, they fail to recognize what *enabled* this behavior. In particular, the results from the *IG* suggest that the low degree of uncertainty in this period interacted with partisan shifts to lead

contingencies, but indeed to expand its jurisdictional reach to concerns wholly different from those that animated the regulation in the first instance."

to changes in tariff policy. In this case, it is possible to use the results in Propositions 1 and 2 to posit a counterfactual: if political uncertainty had been high in this period, partisan changes would not have led to significant shifts in tariff policy.

Table 1. Passage of Major Tariff Legislation, 1890-1934

| <i>Year</i> | <i>Party Control*</i> | <i>Legislation</i> | <i>Impact on Tariffs</i> |
|-------------|-----------------------|--------------------|--------------------------|
| 1890 | Republican | McKinley | Increase |
| 1894 | Democrat | Wilson-Gorman | Decrease |
| 1897 | Republican | Dingley | Increase |
| 1909 | Republican | Payne-Aldrich | Decrease |
| 1913 | Democrat | Underwood | Decrease |
| 1922 | Republican | Fordney-McCumber | Increase |
| 1930 | Republican | Smoot-Hawley | Increase |
| 1934 | Democrat | RTAA | Decrease |

* All periods are of unified party control of the House, Senate and Presidency

Source: Bailey, Goldstein and Weingast (1997).

The tariff case is also supportive of the *IG*. As mentioned, in the late nineteenth century and early twentieth century, the dominant Republican party would undo any reductions in tariffs the Democrats made during infrequent periods of Democratic supremacy. When they again were in a position to legislate tariff policy in the 1930's, they faced a familiar problem: how would they make the changes more durable? They found an answer in the RTAA of 1934. As Bailey, Goldstein and Weingast (1997) argue, the RTAA ceded control over tariff policy from Congress to the President. Given that presidents were inherently more liberal on trade than legislators, the Democrats would ensure that tariffs would be lower than under the usual Republican Congresses. "...[B]y giving the President agenda-setting power, tariff cuts would be more extensive and durable even if congress were

⁴⁰ See also Bailey, Goldstein and Weingast (1995), 5-6. See Table 1 for strong evidence of this pattern.

to be taken back by protectionist forces," they explain. Even Republican Presidents, with their national constituencies, would be more liberal on trade than Republicans in Congress and could use their institutional power to constrain the protectionist impulses of Republicans in Congress" (Bailey, Goldstein and Weingast 1997: 310). Two features of this example are important, then, to illustrate the results from the *IG*. First, as predicted, an electorally weak party, the Democrats, was willing to bear the costs of insulating their agenda in return for a steadier stream of expected benefits. Perhaps more importantly, the Republicans, the dominant party, did not insulate their changes. In their position, incurring a significant cost for insulation would likely be one which they paid on an ongoing basis. They were more content to sabotage the Democratic programs when given the opportunity, and to continue to implement their programs during their frequent times in power.

5. Discussion

Structural choices are crucial to both interest groups and legislators. These choices, however, are made in a process of *strategic interactions* between players set in an institutional context. Moe's analysis of the nature of these choices is at once instructive and incomplete: while political uncertainty, under certain conditions, *can* lead to bureaucratic inefficiency, this occurs only to a point. In many cases, political uncertainty actually *discourages* inefficient insulation of public policy.

The models illustrate the role that electoral volatility plays in the behavior of actors. Frequent turnover among elected officials, depending on the policy in question, can lead to a greater degree of cooperation across generations of these officials. The critical mechanism that results in such cooperation is the employment of punishment strategies. Players whose electoral fates are uncertain are more willing to take conciliatory postures towards their opponents when they believe they will soon have to cede public authority to opposing groups. Although this paper focuses on a particular context for reciprocity—the structural choices by interest groups—its implication extends beyond this application to general theories of democratic representation and policy implementation. Both the *reciprocity game (RG)* and the *insulation game (IG)* suggest a potentially important empirical and theoretical

avenue of research: the nature and manifestations of reciprocity which emerges from democratic institutions.⁴¹

Comparing the models also allows us to examine the implications of two alternative institutional structures on agency organization. In the *RG*, durable insulation is not an available action. As noted earlier, this situation is akin to that of a parliamentary system, in which the *lack* of veto points makes legislation easy to pass. In this context, players will cooperate as uncertainty increases, as groups' power is more evenly divided. In cases where there is a high degree of uncertainty, policies will be the most stable. The *IG* examines the alternative case, when insulation is available to players. Here, if the costs of insulation are not prohibitive, players will never cooperate. Policy stability in this context is established in a different way. Groups that are historically privileged in the electoral arena will not insulate their policies. But since they are in power often, these powerful groups will be able to maintain the continuity of their policies. Groups that are disadvantaged electorally *will* insulate their policies, *in those occasional political moments* that they do rise to control the public apparatus. So although they are infrequently in power, their policies will be stable as well, albeit less effectively implemented (Moe and Caldwell 1994).

The models developed in this paper represent a deeper understanding of the nature of electoral institutions on norms of reciprocity. Unlike earlier attempts, they show the contingent nature of cooperative decisions in the face of ambiguity. They represent a starting point for further theoretical and empirical investigation into the nature of electoral institutions. As shown in the empirical examples, although the models are developed in the context of agency structure, their implications extend beyond that domain. In situations in which the interaction between electoral outcomes and control of public authority provides the opportunity for dynamic punishments, public officials will condition their behavior on the shadow of future elections.

⁴¹ This is not to say that reciprocity has not been posited as an explanation for many phenomenon. Norms in Congress, for example, are in part based on a system of reciprocal transactions. However, in this case, we focus on those equilibria which are generated by electoral uncertainty.

APPENDIX: PROOFS OF RESULTS

A. PROOFS OF PROPOSITION 1 THROUGH 4

PROOF OF PROPOSITION 1. In this case, one must only analyze a subgame in which the other player has moved. For A , her choice at any point is whether or not to play O , given B 's strategy. Notionally, this can occur at any stage of the game, but his choice at the first stage is identical to that at later stages, so one must only consider the first opportunity to overturn. Since B is playing grim trigger, if A plays O , then his expected payoff is given by:

$$EU_A(A_A = O) = 1 + \gamma \sum_{t=1}^{\infty} \delta^t$$

Note that I suppress the subscript t and the conditioning on s_B . The expected payoff, then, can be written:

$$EU_A(A_A = O) = 1 + \frac{\delta\gamma}{1-\delta} = \frac{1-\delta + \delta\gamma}{1-\delta} \quad (2)$$

If A plays NO , however, for all t , his expected payoff is:

$$EU_A(A_A = N) = \beta \sum_{t=0}^{\infty} \delta^t$$

which can be rewritten:

$$EU_A(A_A = N) = \frac{\beta}{1-\delta} \quad (3)$$

Thus, A will cooperate if and only if (3) is greater than (2). Thus, I obtain the condition that A cooperates if and only if

$$\beta > 1 - \delta + \delta\gamma = \beta_A^* \quad (4a)$$

From the symmetry of the game I can obtain a similar result for B , substituting $1 - \gamma$ for γ . Namely, B will cooperate if and only if

$$\beta > 1 - \delta\gamma = \beta_B^* \quad (4b)$$

Since cooperation is sustained only if both players do not have an incentive to play O , and both (4a) and (4b) are lower bounds, I therefore can define a condition such that cooperation can be sustained:

$$\beta > \max(\beta_A^*, \beta_B^*) = \beta^* \quad (5)$$

The proposition follows from the fact that β^* is a function of δ and γ . ■

PROOF OF PROPOSITION 2. Solving for the maximum condition given in (5), I obtain the following:

$$\beta^* = \begin{cases} 1 - \delta + \delta\gamma & \text{if } \gamma > \frac{1}{2} \\ 1 - \delta\gamma & \text{if } \gamma < \frac{1}{2} \end{cases} \quad (6)$$

The proposition follows from the fact that the β^* is a decreasing function of γ if $\gamma < 0.5$ and increasing if $\gamma > 0.5$.⁴² ■

PROOF. To solve for the equilibrium conditions, we again employ the concepts of subgame perfection. Although the insulation choice is a one-shot play, the overturn-not-overturn decision is infinitely repeated. We are evaluating the equilibrium under grim trigger strategies, so each player must choose from the action set $A_t'' = \{(I,O); (I,NO); (NI,O)\}$;

⁴² Since β_A^* and β_B^* are linear in γ , this means that $\beta^*(\delta, \gamma)$ is not differentiable in γ . I ignore this problem by assuming that $\gamma \neq \frac{1}{2}$. Two other points are also useful to note. First, although this result is in terms

(NI,NO) }.⁴³ To find the conditions under which a particular set of strategies is an equilibrium, we evaluate the four potential strategy combinations, having fixed the equilibrium strategy of the other player.

To find the conditions under which both players insulate, we evaluate $\{(I,O);(I,O)\}$. Initially, we evaluate when (I,O) is a best response for A given that B is playing (I,O) . Note first that if B plays (I,O) , (I,O) weakly dominates (I,NO) and strictly dominates (NI,NO) for A . Thus we must compare the expected payoffs for A from (I,O) and (NI,O) . If A plays (I,O) , his expected payoff is given by:

$$EU_A(A_{At}'' = \{(I,O)\} | A_{Bt}'' = \{(I,O)\}) = \sum_{t=0}^{\infty} \alpha \delta^t [\gamma^{t+1} + \beta(1-\gamma^{t+1} - (1-\gamma)^{t+1})]$$

which can be rewritten:

$$EU_A(A_{At}'' = \{(I,O)\} | A_{Bt}'' = \{(I,O)\}) = \frac{\alpha\gamma(1-\beta)}{1-\delta\gamma} + \frac{\alpha\beta}{1-\delta} + \frac{\alpha\beta(1-\gamma)}{1-\delta+\delta\gamma} \quad (7)$$

Similarly, if A plays (NI,O) , his expected payoff is:

$$EU_A(A_{At}'' = \{(NI,O)\} | A_{Bt}'' = \{(I,O)\}) = \sum_{t=0}^{\infty} \delta^t [\gamma^{t+1} + \beta\gamma(1-\gamma^t)]$$

which can be rewritten:

$$EU_A(A_{At}'' = \{(NI,O)\} | A_{Bt}'' = \{(I,O)\}) = \frac{\gamma(1-\beta)}{1-\delta\gamma} + \frac{\beta\gamma}{1-\delta} \quad (8)$$

Solving for the conditions under which the expression in (7) is greater than that in (8), yields:

$$\alpha > \frac{(1-\delta+\delta\gamma)(1-\delta+\beta\delta(1-\gamma))}{(1-\delta+\delta\gamma)(1-\delta)+\beta\delta(2-\delta)(1-\gamma)} = \alpha_A^* \quad (9)$$

of the parameter β , the same holds true for $\delta^*(\beta,\gamma)$. Second, taking the partial derivative of β^* with respect to δ in (6) yields that β^* is decreasing in δ , which indicates that the folk theorem holds for the RG .

⁴³ Implicitly, we are evaluating equilibria in which if a player does not want to overturn in the first turn, he will not do so afterwards.

Thus, if (9) holds, then A 's best response to B playing (I, O) is (I, O) . From the symmetry of the game form and payoffs, we can derive the condition under which B 's best response to A playing (I, O) is (I, O) by substituting $(1-\gamma)$ for γ in (9). We call this cut point α_B^* . Since α must be greater than both α_A^* and α_B^* , we have the result:

$$\{(I, O); (I, O)\} \text{ is an equilibrium} \Leftrightarrow \alpha > \max(\alpha_A^*, \alpha_B^*) = \alpha^* \quad (10)$$

which is the proposition. ■

PROOF. Consider first that $\alpha < \alpha_B^*$. Then from the proof of Proposition 3a above, we have that given that given that A plays (I, O) , B 's best response is $(NI, .)$, so B will not insulate even if A does. We must then compare the expected payoff for A from playing (I, O) versus (NI, O) given that B plays $(NI, .)$.

If A plays (I, O) , his expected payoff is given by:

$$EU_A(A_{At}'' = \{(I, O)\} | A_{Bt}'' = \{(NI, O)\}) = \sum_{t=0}^{\infty} \delta^t \gamma \alpha + \sum_{t=1}^{\infty} \delta^t \alpha \beta (1-\gamma - (1-\gamma)^{t+1})$$

which can be rewritten:

$$EU_A(A_{At}'' = \{(I, O)\} | A_{Bt}'' = \{(NI, O)\}) = \frac{\alpha(\gamma - \delta\gamma(1-\gamma) + \delta\gamma\beta(1-\gamma))}{(1-\delta)(1-\delta + \delta\gamma)} \quad (11)$$

Similarly, if A plays (NI, O) , his expected payoff is:

$$EU_A(A_{At}'' = \{(I, O)\} | A_{Bt}'' = \{(NI, O)\}) = \sum_{t=0}^{\infty} \delta^t \gamma$$

which can be rewritten:

$$EU_A(A_{At}'' = \{(I, O)\} | A_{Bt}'' = \{(NI, O)\}) = \frac{\gamma}{1-\delta} \quad (12)$$

Solving for the conditions under which the expression in (11) is greater than that in (12), yields:

$$\alpha > \frac{1 - \delta + \delta\gamma}{1 - \delta + \delta\gamma + \delta\beta(1 - \gamma)} = \alpha_A^{**} \quad (13a)$$

Thus, if $\alpha < \alpha_B^*$, and (13a) holds, then A will insulate while B will not. By substituting $(1 - \gamma)$ for γ , we can derive a similar result in which B will insulate and A will not if $\alpha < \alpha_A^*$.

$$\alpha > \frac{1 - \delta\gamma}{1 - \delta\gamma + \delta\beta\gamma} = \alpha_B^{**} \quad (13b)$$

(13a) and (13b) constitute the proposition. ■

PROOF. This follows directly from the conditions in (13a) and (13b) above. If $\alpha < \alpha_A^{**}$, then playing (NI) is a best response for A if B plays (NI) . Similarly, if $\alpha < \alpha_B^{**}$, then (NI) is a best response for B given that A plays (NI) . Thus if $\alpha < \min(\alpha_A^{**}, \alpha_B^{**})$, then both players playing (NI) will be an equilibrium. Further, from (5) above, we have a condition under which, given that players are playing $\{(NI, \cdot), (NI, \cdot)\}$, they will overturn if and only if $\beta < \beta^*$. Thus, depending on the value of β , the players that are not insulating will either play O or N . ■

PROOF. To see this consider the conditions given in Propositions 3a through 3c. First note that from Proposition 3a, we have both players insulating if and only if:

$$\alpha > \alpha^* = \begin{cases} \alpha_B^* & \text{if } \gamma < \frac{1}{2} \\ \alpha_A^* & \text{if } \gamma > \frac{1}{2} \end{cases} \quad (14)$$

Taking the first derivative of (14), we obtain the following result:

$$\frac{\partial \alpha^*}{\partial \gamma} \begin{cases} < 0 & \text{if } \gamma < \frac{1}{2} \\ > 0 & \text{if } \gamma > \frac{1}{2} \end{cases} \quad (15)$$

From Proposition 3c, we analyze the behavior of the cutpoints α_A^{**} and α_B^{**} . From (14), we analyze α_A^{**} for γ less than 0.5:

$$\frac{\partial \alpha_A^{**}}{\partial \gamma} = \frac{\delta \beta}{(1 - \delta + \delta \gamma + \delta \beta (1 - \gamma))^2} > 0 \quad (16)$$

Similarly, if γ is greater than 0.5, we examine α_B^{**} :

$$\frac{\partial \alpha_B^{**}}{\partial \gamma} = \frac{-\delta \beta}{(1 - \delta \gamma + \delta \beta \gamma)^2} < 0 \quad (17)$$

(15), (16) and (17), constitute the proposition. ■

B. PROOFS OF OTHER RESULTS

1. FINITE PUNISHMENT PERIODS IN THE RG

PROPOSITION 1 WITH FINITE PUNISHMENT PERIOD. *Given δ and γ , if β is sufficiently high, cooperation can be sustained under the following strategies for both players: if the game is not in a punishment phase, play NO if the other player plays NO in the previous period; if the other player has played O in the previous period, initiate a punishment phase; if the game is in a punishment phase, and it has been initiated by you, play O for T periods when given the opportunity; else play NO.*

PROOF. In this case, we must only analyze a single period deviation to determine when cooperation can be sustained. Here, A 's expected utility from playing O in a non-punishment phase is:

$$EU_A(A_A = O) = 1 + \gamma \sum_{t=1}^T \delta^t$$

The expected payoff, then, can be written:

$$EU_A(A_A = O) = 1 + \frac{\delta\gamma(1-\delta^T)}{1-\delta} = \frac{1-\delta + \delta\gamma(1-\delta^T)}{1-\delta} \quad (18)$$

If A plays NO , his expected payoff in the punishment period is:

$$EU_A(A_A = N) = \beta \sum_{t=0}^T \delta^t$$

which can be rewritten:

$$EU_A(A_A = N) = \frac{\beta\delta(1-\delta^T)}{1-\delta} \quad (19)$$

Thus, A will cooperate if and only if (19) is greater than (18). Thus, I obtain the condition that A cooperates if and only if

$$\beta > \frac{1-\delta + \delta\gamma(1-\delta^T)}{\delta(1-\delta^T)} = \beta_A^* \quad (20a)$$

From the symmetry of the game I can obtain a similar result for B , substituting $1-\gamma$ for γ . Namely, B will cooperate if and only if

$$\beta > \frac{1-\delta + \delta(1-\gamma)(1-\delta^T)}{\delta(1-\delta^T)} = \beta_B^* \quad (20b)$$

Since cooperation is sustained only if both players do not have an incentive to play O , and both (20a) and (20b) are lower bounds, I therefore can define a condition such that cooperation can be sustained:

$$\beta > \max(\beta_A^*, \beta_B^*) = \beta^* \quad (21)$$

The proposition follows from the fact that β^* is a function of δ and γ . ■

Notice that grim trigger, which is equivalent to T approaching infinity, is simply a special case of this more general result.

PROPOSITION 2 WITH FINITE PUNISHMENT PERIOD. *With a T period punishment strategy, as γ approaches 0.5, cooperation can be sustained over a wider range of the parameters.*

PROOF. Solving for the maximum condition given in (5), we obtain the following:

$$\beta^* = \begin{cases} \beta_A^* & \text{if } \gamma > \frac{1}{2} \\ \beta_B^* & \text{if } \gamma < \frac{1}{2} \end{cases} \quad (22)$$

The proposition follows from the fact that the β^* is a decreasing function of γ if $\gamma < 0.5$ and increasing if $\gamma > 0.5$. ■

2. THE RG WITH NEGATIVE QUADRATIC UTILITY FUNCTIONS

PROOF THAT PROPOSITIONS 1 AND 2 HOLD WITH NEGATIVE QUADRATIC UTILITY FUNCTIONS.

Let the structure of the game be identical to the *RG* except that $u_i = -(x - x_i)^2$ $i \in \{A, B\}$ where, without loss of generality, the players' ideal points are $x_A = 0$ and $x_B > 0$. Substituting into (3) above and following the analysis, we obtain that *A* will cooperate iff

$$x \in \{-x_B\sqrt{\delta(1-\gamma)}, x_B\sqrt{\delta(1-\gamma)}\} \quad (23)$$

and *B* will cooperate iff

$$x \in \{x_B(1 - \sqrt{\delta\gamma}), x_B(1 + \sqrt{\delta\gamma})\} \quad (24)$$

Since the set of cooperative regions must overlap, the upper bound in (23) must be higher than the lower bound in (24), a condition we can write

$$x_B \sqrt{\delta(1-\gamma)} - x_B(1-\sqrt{\delta\gamma}) \geq 0 \quad (25)$$

Taking the first derivative of the left hand side of (25), it is clear that holding the other parameters constant, the expression is increasing in δ , implying that as the players' become more patient, it is easier to sustain cooperation (or alternatively, the set of cooperative equilibria expands), which is Proposition 1. Further, we can also consider the conditions on γ in which the cooperative region is maximized. Here, if we take

$$\max_{\gamma} x_B \sqrt{\delta(1-\gamma)} - x_B(1-\sqrt{\delta\gamma})$$

we obtain the condition

$$-\frac{1}{2} \frac{x_B \delta}{\sqrt{\delta(1-\gamma)}} - \frac{1}{2} \frac{x_B \delta}{\sqrt{\delta\gamma}} = 0 \quad \Rightarrow \gamma = 0.5 \quad (26)$$

which is analogous to Proposition 2. ■

3. THE RG WITH N VETO PLAYERS

PROOF THAT PROPOSITION 2 HOLDS WITH N VETO PLAYERS.

To show that Proposition 2 holds for n veto players, it is sufficient to show that the minimum β required for the stronger player to cooperate is increasing in her electoral probability. Without loss of generality assume $\gamma > 0.5$. Let p_{At} be the probability that A 's program will be in place in period t . Thus, we can write A 's payoff for defection as

$$u_{A\infty} = 1 + \sum_{t=1}^{\infty} \delta^t p_{At} \quad (27)$$

This implies that if p_{At} is increasing in γ then β^* is increasing in γ . The general form for p_{At} can be written

$$p_{At} = p_{A(t-1)}(1 - (1 - \gamma)^n) + (1 - p_{A(t-1)})\gamma^n \quad (28)$$

Taking the first derivative of (28), we have

$$\frac{\partial p_{At}}{\partial \gamma} = \frac{\partial p_{A(t-1)}}{\partial \gamma} (1 - (1 - \gamma)^n) + np_{A(t-1)}(1 - \gamma)^{n-1} - \frac{\partial p_{A(t-1)}}{\partial \gamma} \gamma^n + n(1 - p_{A(t-1)})\gamma^{n-1}$$

which can be rewritten

$$\frac{\partial p_{At}}{\partial \gamma} = \frac{\partial p_{A(t-1)}}{\partial \gamma} (1 - (1 - \gamma)^n - \gamma^n) + np_{A(t-1)}(1 - p_{A(t-1)})(1 - \gamma)^{n-1}\gamma^{n-1} \quad (29)$$

Thus, (29) implies that

$$\frac{\partial p_{At}}{\partial \gamma} > 0 \quad \text{if} \quad \frac{\partial p_{A(t-1)}}{\partial \gamma} > 0. \quad (30)$$

By induction, (30) holds if $\frac{\partial p_{A1}}{\partial \gamma} > 0$. As argued previously,

$$p_{A1} = 1 - (1 - \gamma)^n \quad (31)$$

which is increasing in γ . The result when $\gamma > 0.5$ follows from (27) and for $\gamma < 0.5$ by symmetry. ■

4. A ZERO-SUM IG

Here I introduce a modification to the *IG* which changes the payoff-structure to a single dimension. This allows the modeling of one form of a zero-sum game, which might be appropriate for certain empirical situations. To wit, this zero-sum insulation game (*ZIG*) is identical to the *IG* in all but one respect. Now, the payoffs if neither is insulating are as

follows: if A 's program is in place by itself, the payoffs are $(1,0)$; if both A and B 's programs are in place, the payoffs are $(\beta, 1-\beta)$; and if B 's program is in place by itself, the payoffs are $(0,1)$. As before, if a player plays I , he ensures that her program is in place in every stage thereafter, but her payoffs are modified by a factor α , where $\alpha < 1$. In this case, the proofs are similar to those for Propositions 3a, 3b, 3c, and 4.

PROPOSITION A3a. *In the ZIG, if α is sufficiently large, both players will play $\{(I,O)\}$.*

PROOF. Here, the expected payoffs for A are identical to those given in (7). Thus, it is still the case that if the condition given in (9) holds, A 's best response to B playing (I,O) is (I,O) . We call the cutpoint for A α'_A . The difference in the ZIG is that B 's payoffs are no longer the same as A 's around $\gamma=0.5$. While A 's cutpoint for insulation remains the same, it is necessary to reconsider the conditions under which B will insulate. We can solve for the condition under which B 's best response to (I,O) is (I,O) by noticing that since the game form is the same as in the IG except for the payoffs and reelection probabilities, we must only substitute $(1-\gamma)$ for γ and $(1-\beta)$ for β into (9) to obtain a similar condition for B . Making these substitutions, we obtain, B 's best response to A playing (I,O) is (I,O) , if and only if

$$\alpha > \frac{1-\gamma + 2\beta\delta\gamma - \delta - \delta\gamma}{1-\gamma - \delta + \beta\delta\gamma} = \alpha'_B \quad (32)$$

Since α must be greater than both α'_A and α'_B , we have the result:

$$\{(I,O);(I,O)\} \text{ is an equilibrium} \iff \alpha > \max(\alpha'_A, \alpha'_B) = \alpha' \quad (33)$$

which is the proposition. ■

PROPOSITION A3b. *In the ZIG, if α is not sufficiently large for both players to play $\{(I,O)\}$, then an equilibrium for the IG is either $\{(I,O);(NI,O)\}$ or $\{(NI,O);(I,O)\}$ if α is sufficiently large.*

PROOF. The case for A is the same as in Proposition 3b. From (13a) we have

$$\alpha > \frac{1 - \delta + \delta\gamma}{1 - \delta + \delta\gamma + \delta\beta(1 - \gamma)} = \alpha_A'' \quad (34a)$$

Thus, if $\alpha < \alpha_B'$, and (34a) holds, then A will insulate while B will not. By substituting $(1 - \gamma)$ for γ and $(1 - \beta)$ for β in (34a), we can derive a similar result in which B will insulate and A will not. In particular, if $\alpha < \alpha_A'$, A will play (NI, O) whether or not B plays (I, O) or (NI, O) . Given that A plays (NI, O) , B will play (I, O) if and only if

$$\alpha > \frac{1 - \delta\gamma}{1 - \delta\beta\gamma} = \alpha_B'' \quad (34b)$$

(34a) and (34b) constitute the proposition. ■

PROPOSITION A3c. *In the ZIG, if α is sufficiently small, then neither player will insulate.*

PROOF. This follows from (32), (33), (34a) and (34b). The proof is perfectly analogous to that of Proposition 3c. ■

Notice that in general, Proposition 4 does not have an analog in the ZIG. For example, α' might not have a vertex at 0.5. Instead, it is possible that because of the asymmetric nature of the payoffs, the vertex will be either lesser or greater than 0.5 depending on the values of β and δ . The same is true for α'' . This means that in a zero-sum setting, while for most values of γ , as political uncertainty increases, both the both insulate and neither insulate equilibria can be supported by a larger set of the parameters, there can be a region $(\gamma^*, 0.5)$ for which the cooperative space *decreases*.

References

- Alesina, Alberto and Allan Drazen. 1991. "Why Are Stabilizations Delayed?" *American Economic Review* 81 (December): 1170-1188.
- Arnold, Douglas. 1990. *The Logic of Congressional Action*. New Haven, CT: Yale University Press.
- Axelrod, Robert. 1984. *The Evolution of Cooperation*. New York: Basic Books.
- Bailey, Michael A., Judith Goldstein and Barry R. Weingast. 1997. "The Institutional Roots of American Trade Policy: Politics, Coalitions and International Trade." *World Politics* 49 (April): 309-338.
- Bawn, Kathleen. 1995. "Political Control Versus Expertise: Congressional Choices About Administrative Procedures." *American Political Science Review* 89 (March): 62-73.
- Bendor, Jonathan. 1989. "Review Article: Formal Models of Bureaucracy." *British Journal of Political Science* 18: 353-394.
- Bendor, Jonathan and Dilip Mookherjee. 1987. "Institutional Structure and the Logic of Ongoing Collective Action." *American Political Science Review* 81 (March): 133-147.
- Besley, Timothy and Stephen Coate. 1998. "Sources of Inefficiency in a Representative Democracy: A Dynamic Analysis." *American Economic Review* 88 (March): 139-156.
- Brady, David W. and Craig Volden. 1998. *Revolving Gridlock: Politics and Policy from Carter to Clinton*. Boulder, CO: Westview Press.
- Calvert, Randall L. 1989. "Reciprocity among Self-Interested Actors: Uncertainty, Asymmetry and Distribution." In *Models of Strategic Choice in Politics*, ed. Peter C. Ordeshook. Ann Arbor, MI: University of Michigan Press.
- Calvert, Randall L., Matthew D. McCubbins, and Barry R. Weingast. 1989. "A Theory of Political Control and Agency Discretion." *American Journal of Political Science* 33 (August): 588-611.
- Cass, Ronald A. 1989. "Titles IV, V, and VI: Review, Enforcement, and Power under the Communications Act of 1934: Choice and Chance in Institutional Design." In *A Legislative History of the Communications Act of 1934*, ed. Max D. Paglin. Oxford: Oxford University Press.

- Coate, Stephen and Stephen Morris. 1999. "Policy Persistence." *American Economic Review* 89 (December): 1327-1136.
- de Figueiredo, Rui J. P., Jr., Pablo T. Spiller and Santiago Urbiztondo. "An Informational Perspective on Administrative Procedures." *Journal of Law, Economics and Organization* 15 (April): 283-305.
- Dodd, Lawrence C. and Richard L. Schott. 1979. *Congress and the Administrative State*. New York: John Wiley.
- Eads, George C. and Kozo Yamamura. 1987. "The Future of Industrial Policy." In *The Political Economy of Japan: The Domestic Transformation*, ed. Kozo Yamamura and Yasukichi Yasuba. Stanford, CA: Stanford University Press.
- Emery, Walter B. 1971. *Broadcasting and Government: Responsibilities and Regulations*. Lansing, MI: Michigan State University Press.
- Epstein, David and Sharyn O'Halloran. 1994. "Administrative Procedures, Information and Agency Discretion." *American Journal of Political Science* 38 (August): 697-722.
- Epstein, David and Sharyn O'Halloran. 1996. "The Partisan Paradox and the U. S. Tariff, 1877-1934." *International Organization* 50 (Spring): 301-324.
- Epstein, David and Sharyn O'Halloran. 1999. *Delegating Powers: A Transaction Cost Politics Approach to Policy Making under Separate Powers*. Cambridge, MA: Harvard.
- Ferejohn, John A. and Charles R. Shipan. 1983. "Congressional Influence on Administrative Agencies: A Case Study of Telecommunications Policy." In *Congress Reconsidered*, 2nd edition, ed. Lawrence C. Dodd and Bruce I. Oppenheimer. Washington, DC: Congressional Quarterly Press.
- Fiorina, Morris P. 1983. "Congressional Control of the Bureaucracy: A Mismatch of Incentives and Capabilities." In *Congress Reconsidered*, 2nd edition, ed. Lawrence C. Dodd and Bruce I. Oppenheimer. Washington, DC: Congressional Quarterly Press.
- Fudenberg, Drew and Jean Tirole. 1991. *Game Theory*. Cambridge, MA: MIT Press.
- Hamilton, Alexander, John Jay, and James Madison. 1961. *The Federalist Papers*. Selected and edited by Clinton Rossiter. New York: Penguin.
- Hamilton, Alexander, John Jay, and James Madison. 1966. *The Federalist Papers*. Selected and edited by Roy P. Fairfield. Baltimore: Johns Hopkins University Press.

Horn, Murray. 1995. *The Political Economy of Public Administration: Institutional Choice in the Public Sector*. Cambridge: Cambridge University Press.

Johnson, Chalmers. 1982. *MITI and the Japanese Miracle: The Growth of Industrial Policy*. Stanford, CA: Stanford University Press.

Kiewiet, D. Roderick and Matthew D. McCubbins. 1991. *The Logic of Delegation: Congressional Parties and the Appropriations Process*. Chicago: University of Chicago.

Krehbiel, Keith. 1998. *Pivotal Politics: A Theory of U.S. Lawmaking*. Chicago: University of Chicago Press.

Kreps, David. 1992. *A Course in Microeconomic Theory*. Princeton, NJ: Princeton University Press.

Lupia, Arthur, and Mathew D. McCubbins. 1994. "Designing Bureaucratic Regulation." *Law and Contemporary Problems* 57: 91-126.

Mahan, Mary Elizabeth. 1982. *Commercial Broadcast Regulation: Structures and Processes in Mexico and the United States*. Ph. D. dissertation. University of Texas at Austin.

McCubbins, Matthew D., Roger G. Noll, and Barry R. Weingast. 1987. "Administrative Procedures as Instruments of Political Control." *Journal of Law, Economics and Organization* 3 (Fall): 243-277.

McCubbins, Matthew D., Roger G. Noll, and Barry R. Weingast. 1989. "Structure and Process; Politics and Policy: Administrative Arrangements and the Political Control of Agencies." *Virginia Law Review* 75: 431-482.

McMahon, Robert Sears. 1979. *Federal Regulation of the Radio and Television Broadcast Industry in the United States, 1927-1959: With Special Reference to the Establishment and operation of Workable Administrative Standards*. New York: Arno Press.

Moe, Terry M. 1989. "The Politics of Bureaucratic Structure." In *Can the Government Govern?* ed. John E. Chubb and Paul E. Peterson. Washington, DC: Brookings.

Moe, Terry M. 1990. "The Politics of Structural Choice: Towards a Theory of Public Bureaucracy." In *Organization Theory: From Chester Barnard to the Present and Beyond*, ed. Oliver E. Williamson. Berkeley, CA: University of California Press.

Moe, Terry M. 1991. "Politics and the Theory of Organization." *Journal of Law, Economics and Organization* 7 (Special): 106-129.

- Moe, Terry M. and Michael Caldwell. 1994. "The Institutional Foundations of Democratic Government: A Comparison of Presidential and Parliamentary Systems." *Journal of Institutional and Theoretical Economics* 150 (March): 171-195.
- Morrow, James D. 1994. *Game Theory for Political Scientists*. Princeton, NJ: Princeton University Press.
- Muramatsu, Michio and Ellis S. Krauss. 1987. "The Conservative Policy Line and the Development of Patterned Pluralism." In *The Political Economy of Japan: The Domestic Transformation*, ed. Kozo Yamamura and Yasukichi Yasuba. Stanford, CA: Stanford University Press.
- Niskanen, William. 1971. *Bureaucracy and Representative Government*. New York: Basic Books.
- Ordeshook, Peter C. 1986. *Game Theory and Political Theory: An Introduction*. Cambridge: Cambridge University Press.
- Robinson, Glenn O. 1989. "Title I: The Federal Communications Act: An Essay on Origins and Regulatory Purpose." In *A Legislative History of the Communications Act of 1934*, ed. Max D. Paglin. Oxford: Oxford University Press.
- Rothenberg, Lawrence S. 1994. *Regulation, Organization and Politics: Motor Freight Policy at the Interstate Commerce Commission*. Ann Arbor, MI: University of Michigan Press.
- Stigler, George. 1972. "Theory of Economic Regulation." *Bell Journal of Economics* 2: 3-21.
- Tirole, Jean. 1986. "Hierarchies and Bureaucracies: On the Role of Coercion in Organizations." *Journal of Law, Economics and Organization* 2 (Fall): 181-214.
- Tsebelis, George. 1995. "Decision Making in Political Systems: Veto Players in Presidentialism, Parliamentarism, Multicameralism and Multipartyism." *British Journal of Political Science* 25 (July): 289-345.
- United States Congress. 1927. *Radio Act of 1927*. Washington, DC: Government Printing Office.
- United States Congress. 1934. *Communications Act of 1934*. Washington, DC: Government Printing Office.
- United States Congress. 1932. *Congressional Record—House, February 10, 1932*. Washington, DC: Government Printing Office.

United States Congress. House Committee on Interstate and Foreign Commerce. 1934. *Hearings: Federal Communications Commission*. April 10. Washington, D.C.: Government Printing Office.

United States Congress. Senate Committee on Interstate Commerce. 1934. *Hearings: Federal Communications Commission*. March 9, 10, 13, 14 and 15. Washington, D.C.: Government Printing Office.

United States Department of Commerce, Bureau of the Census. 1975. *Historical Statistics of the United States: Colonial Times to 1970, Vols. 1 and 2*. Washington, DC: Government Printing Office.

Vogel, David. 1989. *Fluctuating Fortunes: The Political Power of Business in America*. New York: Basic Books.

Weingast, Barry R. 1984. "The Congressional-Bureaucratic System: A Principal Agent Perspective (With Applications to the SEC)." *Public Choice* 44: 147-191.

Weingast, Barry R. and Mark J. Moran. 1983. "Bureaucratic Discretion or Congressional Control? Regulatory Policymaking by the Federal Trade Commission." *Journal of Political Economy* 91 (October): 765-800.

Wilson, James Q. 1989. *Bureaucracy: What Government Agencies Do and Why They Do It?* New York: Basic Books.

Wollenberg, J. Roger. 1989. "Title III: The FCC as Arbiter of 'The Public Interest, Convenience, and Necessity.'" In *A Legislative History of the Communications Act of 1934*, ed. Max D. Paglin. Oxford: Oxford University Press.